



**USER MANUAL FOR PELLET BOILER
ELEGANT 27 AND 37KW**

1. Technical characteristics

DESCRIPTION		Unit	Elegant27	Elegant37
Power		kw	27	37
Boiler volume		lit	45	96
Required draft		Pa	10	10
Power supply				
- during ignition phase		W	450	450
- during operation phase		W	150	150
Supply voltage		V	230	230
Frequency		Hz	50	50
Boiler mass		kg	260	410
Maximum operating pressure		bar	2.5	2.5
Maximum operating temperature		°C	85	85
Flue pipe diameter		mm	120	120
Fireplace dimensions		Width	mm	581
		Height	mm	1318
		Depth	mm	845
Fireplace connections	Flow	Col	1"	5/4"
	Return	Col	1"	5/4"
Pellet hopper capacity		kg	35*	95

*Option to install an additional pellet hopper with a capacity of 65 kg

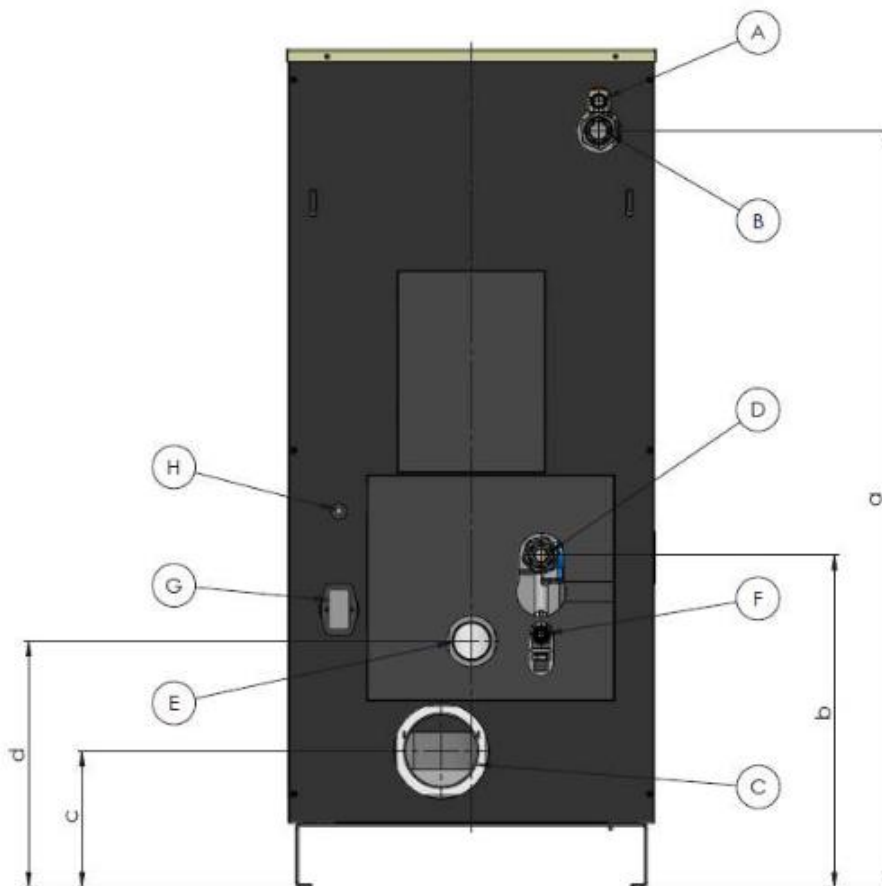

A	Safety valve	1/2"SN 3bar
B	Flow pipe	Hot water 1" – 5/4"
C	Flue connection	Ø 120mm
D	Return pipe	Cold water 1" – 5/4"
E	Fresh air intake connection	Ø 60.3 mm
F	Filling and draining tap	
G	Main switch	
H	Safety thermostat	

Connection dimensions

		27kw	37kw
a	Flow pipe	1091mm	1466mm
b	Return pipe	522mm	580mm
c	Flue connection	215mm	215mm
d	Fresh air intake	387mm	442mm

Overall dimensions:

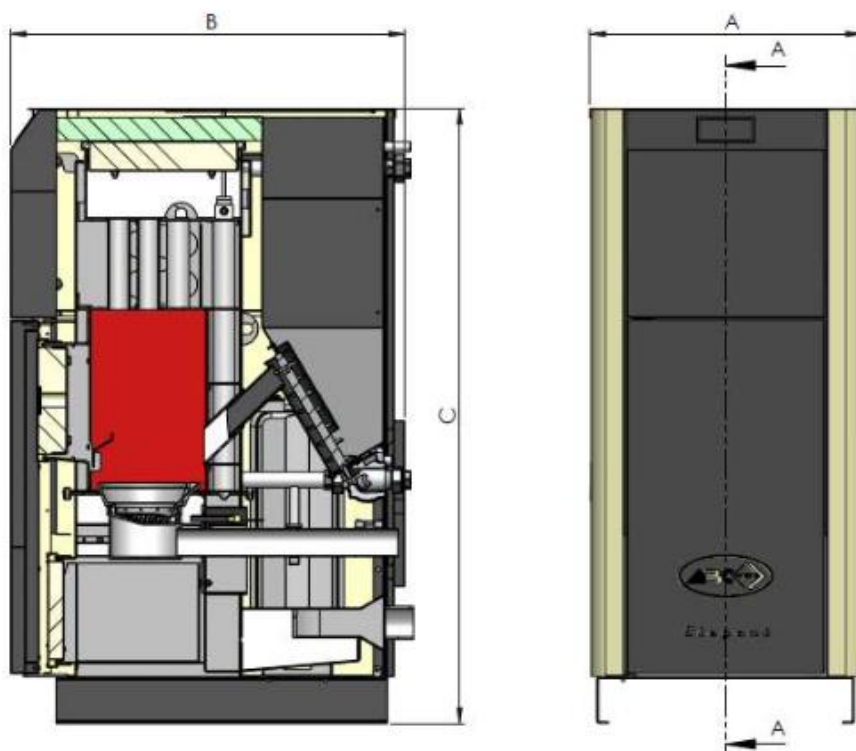

	Elegant 27kw	Elegant 37kw
A	581mm	770
B	845mm	1045
C	1318mm	1600

2. Display: Functions and use

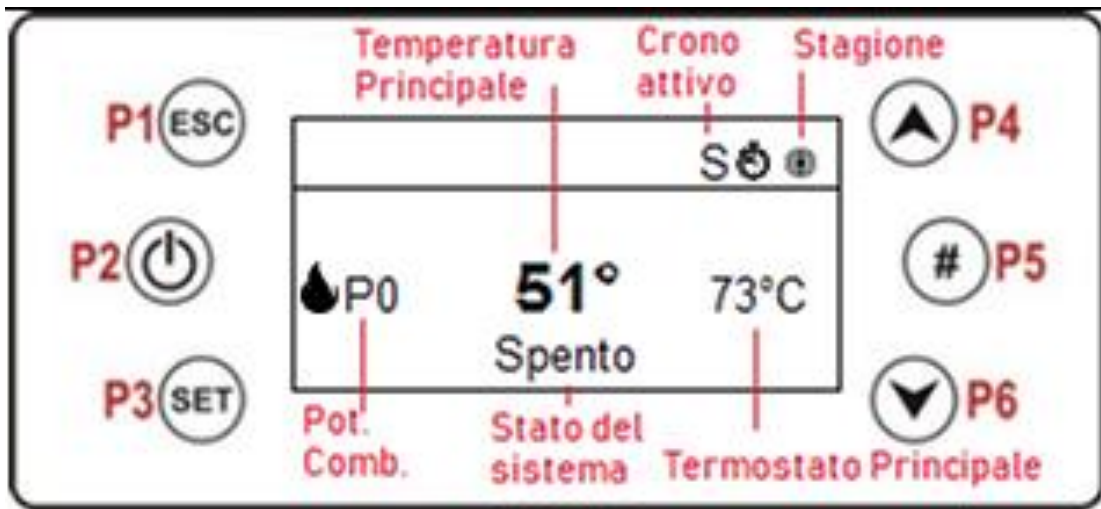

P1	Exit menu (submenu)	P4	Adjust combustion power +
P2	Power on, power off, error reset (press and hold for 3 seconds) Activate chrono function	P5	Activate chrono time setting Access info menu
P3	Access user menu 1 and user menu 2 (press and hold) Save settings	P6	Adjust water temperature -
P3 + P5 (press and hold)	Direct access to secondary information		

Led

D ☀	Daily chrono active	🚰	Domestic hot water/buffer demand not satisfied
W ☀	Weekly chrono active		
WE ☀	Weekend chrono active		
☀	Summer operating mode	❄️	Winter operating mode
C	Combined mode (inactive)	🔥	Wood-burning mode
🏠	Climatic function (inactive)	🌡️	Room thermostat

3. Alarms

DESCRIPTION	STATUS	CODE
Safety thermostat HV1	Blocked	Er 01
Boiler door open / Safety pressure switch	Blocked	Er 02
Shutdown - low flue gas temperature		Er 03
Shutdown - high boiler water temperature		Er 04
Shutdown - high flue gas temperature		Er 05
Pellet thermostat open / high temperature in pellet hopper		Er 06
No encoder signal		Er 07
Fan speed regulation failed		Er 08
Low water pressure		Er 09
High water pressure		Er 10
Time and date not set		Er 11
Ignition failed		Er 12
Power supply missing		Er 15
RS 485 communication error		Er 16
Domestic hot water/buffer/boiler probe open		Er 23

4. Visualisation

Description	Message
Probe error during "Check Up" phase	Probe
Periodic cleaning in progress	Cleaning on
System operating in night mode	Night mode
Display firmware not compatible with motherboard	Keyboard not compatible

5. User menu

Operating mode	<p>This menu allows you to change the system operating mode, i.e., switch between wood and pellet operation, or select the combined mode. The menu is displayed only if P11 = 2, 3, or 4.</p> <p>Switching from one operating mode to another is possible only in the following cases:</p> <p>From the OFF state, any of the following options can be selected</p> <p>With the system ON and P11 = 2, the operating mode cannot be changed</p> <p>With the system ON and P11 = 3, it is possible to switch from wood mode to combined mode</p> <p>With the system ON and P11 = 4, it is possible to switch from wood mode to combined mode</p>
Power	<p>PELLET</p> <p>This menu allows you to adjust the combustion power in pellet mode. It can be set in automatic or manual mode: In automatic mode, the system selects the combustion power; in manual mode, the user selects the desired power</p> <p>The left side of the display shows the combustion mode (A = automatic, M = manual) and the system's operating power.</p> <p>In burner systems, automatic power cannot be set. The menu is displayed if P11 is not equal to 1.</p> <p>WOOD</p> <p>This menu allows you to adjust the combustion power in wood mode. It can be set in automatic or manual mode: In automatic mode, the system selects the combustion power; in manual mode, the user selects the desired power The left side of the display shows the combustion mode (A = automatic, M = manual) and the system's operating power. In burner systems, automatic power cannot be set. The menu is displayed if A36 = 1 and P11 is not 0.</p> <p>HEATING</p> <p>This menu allows you to adjust the heating power. It can be set in automatic or manual mode: In automatic mode, the system selects the combustion power; in manual mode, the user selects the desired power</p> <p>The menu is not displayed if no output is set as a heating fan or if parameter A04 = 1.</p>
Thermostat	<p>This menu allows you to adjust the values of the main thermostats. The menu is not displayed in burner systems.</p> <p>BOILER</p> <p>This menu allows you to adjust the boiler thermostat values. Minimum and maximum values can be programmed by setting thermostats Th26 and Th27. When the climatic function is enabled, the thermostat value cannot be changed, as it is calculated automatically by the system. The menu is displayed only if the boiler probe is installed.</p> <p>DHW</p> <p>This menu allows you to adjust the domestic hot water thermostat; it is displayed if the hydraulic system is set as a domestic hot water tank. Minimum and maximum values can be programmed by setting thermostats Th51 and Th52.</p> <p>BUFFER</p> <p>This menu allows you to adjust the buffer tank thermostat; it is displayed if</p>

	<p>the selected hydraulic system includes a buffer tank. Minimum and maximum values can be programmed by setting thermostats Th51 and Th52.</p> <p>When the climatic function is enabled, its value cannot be changed, as it is calculated automatically by the system</p>								
<p>Chrono</p>	<p>Enables the programming and system power on/off. It consists of 2 submenus</p> <div style="display: flex; justify-content: space-between;"> <div data-bbox="271 324 941 1892" style="width: 60%;"> <p>OPERATING MODE Allows selection of the desired mode or the disabling of all programming.</p> <ul style="list-style-type: none"> • Enter the editing mode using the P3 button. • Select the desired mode (daily, weekly, or weekend). • Save the new settings using the P3 button. <p>PROGRAM The system offers three types of programming: daily, weekly, weekend. After selecting the desired programming type:</p> <ul style="list-style-type: none"> • Select the time you wish to program using the P6 or P4 button. • Enter editing mode (the selected time will flash) using the P3 button. • Modify the times using the P6 or P4 button. • Save the programming using the P3 button. • Enable (“V” is displayed) or disable the time slot (“V” is not displayed) by pressing the P5 button. <p>DAILY Select the day of the week you wish to program and set the power on and power off times. <i>Programming past midnight</i> Set the previous day’s power on time to the desired value, e.g. 20:30 Set the previous day’s power off time to 23:59. Set the next day’s power on time to 00:00. Set the next day’s power off time to the desired value, e.g. 06:30 The system will turn on at 20:30 on Tuesday and turn off at 6:30 on Wednesday.</p> <p>WEEKLY The program is the same for all days of the week.</p> <p>WEEKEND Select between Monday to Friday and Saturday to Sunday and set the power on and power off times.</p> </div> <div data-bbox="941 324 1284 1892" style="width: 35%; border: 1px solid black; padding: 5px;"> <div style="border: 1px solid black; padding: 5px; margin-bottom: 10px;"> <p>Deactivated</p> <p>Daily</p> <p>Weekly</p> <p>Weekend</p> </div> <div style="border: 1px solid black; padding: 5px; margin-bottom: 10px;"> <p>Monday</p> <table style="width: 100%; border-collapse: collapse;"> <thead> <tr> <th style="width: 50%; text-align: center;">ON</th> <th style="width: 50%; text-align: center;">OFF</th> </tr> </thead> <tbody> <tr> <td style="text-align: center;">09:30</td> <td style="text-align: center;">11:15 V</td> </tr> <tr> <td style="text-align: center;">00:00</td> <td style="text-align: center;">00:00</td> </tr> <tr> <td style="text-align: center;">00:00</td> <td style="text-align: center;">00:00</td> </tr> </tbody> </table> </div> <div style="border: 1px solid black; padding: 5px; margin-bottom: 10px;"> <p>Monday</p> <p>Tuesday</p> <p>Wednesday</p> <p>Thursday</p> </div> <div style="border: 1px solid black; padding: 5px;"> <p>Mon-Fri</p> <p>Sat-Sun</p> </div> </div> </div>	ON	OFF	09:30	11:15 V	00:00	00:00	00:00	00:00
ON	OFF								
09:30	11:15 V								
00:00	00:00								
00:00	00:00								

5.1. User Menu 2

Settings	Date and Time Allows setting the current day, month, year, and time.	
	Language Selection Menu for changing the control panel/display language.	
	Recipe Menu for selecting the combustion recipe; if P04=1, the menu is not displayed.	
	Summer – Winter This menu allows adjustment of the hydraulic system operation according to the season. Displayed only if the system is hydraulic.	
Service	Counters	
	Ignitions	Total number of ignitions.
	Ignitions failed	Total number of ignitions failed.
	Operating Hours	Operating hours in working, modulation, and safety modes.
	Error List The menu displays the last 10 errors; each row shows the error code and the date/time of the error. Enter the counter reset menu to clear this list.	
	Secondary Information Information on configurable outputs and inputs is available only if previously set.	
	<i>Display</i>	<i>Description</i>
	592	NG01 Wood-Pellet Evo Code.
	xyzt	Manufacturer code
	Fan	Flue fan speed (output V1)
	Output (C)	Output status (On/Off) or reducer speed (rpm) if P81=1, 2 and the output is set as a reducer.
	Output (V2)	Output status (On/Off).
	Output (A1)	Output status (On/Off).
	Output (A2)	Output status (On/Off).
	Output (PW1)	Output status (On/Off).
	Output (PW2)	Output status (On/Off).
	Air flow	Air flow: displayed if the input is set as primary air regulator.
	Flue Gas T	Flue gas temperature.
	Water T.	Boiler temperature. Displayed only if the system is hydraulic.
	Buffer T	Buffer tank temperature: displayed if the input is set as DHW/buffer tank probe and hydraulic system with buffer tank is selected.
DHW T	DHW temperature: displayed if the input is set as DHW tank probe and a hydraulic system with DHW tank is selected.	
Input (IN2)	Input status (digital only): open->0, closed->1.	
Input (IN3)	Input status (digital only): open->0, closed->1.	
Input (IN4)	Input status (digital only): open->0, closed->1.	
Input (IN6)	Input status (digital only): open->0, closed->1.	
Input (IN7)	Input status (digital only): open->0, closed->1.	
Input (HV1)	Output status: open->0, closed->1.	
Input (HV2)	Output status: open->0, closed->1.	

	<p>Reducer Calibration This menu allows you to adjust the default reducer speed or activation time. Adjustable values range from -7 to 7, with 0 as the default. The menu is displayed only if A64 = or 4.</p> <p>Fan Calibration This menu allows you to adjust the default combustion fan speed. Adjustable values range from -7 to 7, with 0 as the default. The menu is displayed only if A64 = or 4.</p> <p>Automatic combustion power This menu allows you to set the combustion power in automatic mode only. Once configured, the menus for manual power adjustment are hidden. The menu is not displayed in burner systems.</p> <p>Pellet Loading This procedure activates manual pellet loading and automatically stops after 300 seconds. The system must be OFF for the function to operate.</p>
<p>Display</p> <p>System Menu</p>	<p>Contrast Allows adjustment of the screen contrast.</p> <p>Audio Alarm Menu for enabling or disabling the audible alarm.</p> <p>Firmware Codes This menu displays the control board's communication address, board type, and firmware versions. Possible board types include: MSTR Master INP inputs KEYB keyboard OUT outputs CMPS composite SENS sensors COM communication</p> <p>Control Board Address Password-protected menu (default password 1810) used to set the RS485 node address. No two nodes on the 485 bus can share the same address.</p> <p>Minimum Backlight Allows adjustment of the screen brightness when controls are not in use. Menu for accessing data reserved for technical personnel. Access is password-protected.</p>

6.1. Hydraulic System Selection

By setting parameter P26, it is possible to select the most suitable hydraulic system configuration.

System Pump Lock via Room Thermostat:

- Available above the thermostat value for pump activation Th19 or Th59 (for system 4).
- In systems 0 and 2, if there is a demand for water, pump P1 is not blocked and will reactivate if it was previously locked.

Electrical Connections:

- S1 = boiler probe
- S2 = water heater/buffer probe
- FL = flow regulator
- P1 = pump P1
- P2 = pump P2/solenoid valve

Configuration 0

By setting parameter **P26 = 0**, the configuration shown in Figures 1 and 2 is selected.

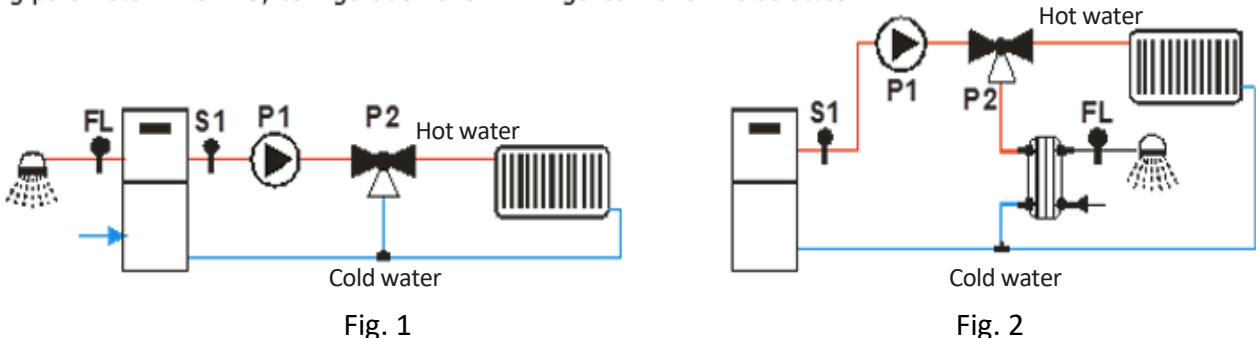

Heating

The pump activates when the temperature exceeds the Th20 thermostat setting; to prevent water freezing, it also activates if the water temperature falls below the Th18 thermostat setting. If the water temperature exceeds the Th21 thermostat setting, the pump remains active for safety reasons.

Water Recirculation

When there is domestic hot water demand and the boiler water temperature exceeds the Th19 thermostat setting, or when the boiler water temperature exceeds the Th20 thermostat setting, the valve opens.

If the water temperature exceeds the Th21 thermostat setting, the valve directs the water to the system.

Example: Th18 = 5 °C, Th19 = 40 °C, Th20 = 30 °C, Th21 = 70 °C

Configuration 1

By setting parameter P26=1, the configuration shown in Figures 3 and 4 is selected:

Water temperature	Flow regulator	Model	Operating mode	Valve P2	Pump P1
$T < 5^{\circ}\text{C}$	-	-	-	system (OFF)	ON
$5^{\circ}\text{C} \leq T < 30^{\circ}\text{C}$	-	-	-	system (OFF)	OFF
$30^{\circ}\text{C} \leq T < 40^{\circ}\text{C}$	-	-	-	recirculation (ON)	ON
$40^{\circ}\text{C} \leq T < 70^{\circ}\text{C}$	Open	Winter	Pellet	system (OFF)	ON
		Summer	Pellet	recirculation (ON)	OFF
	Closed	-	Wood	system (OFF)	ON
$T \geq 70^{\circ}\text{C}$	-	-	-	system (OFF)	ON

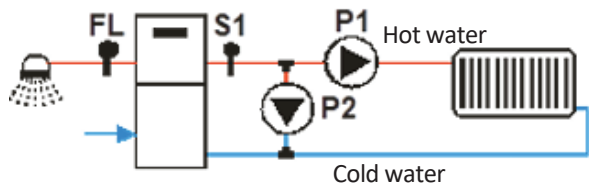

Fig. 3

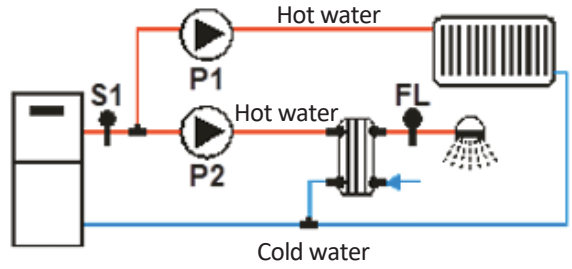

Fig. 4

Heating

Pump P1 activates when the temperature exceeds the Th19 pump activation thermostat and is blocked if there is a domestic hot water demand.

To prevent freezing, Pump P1 also activates if the water temperature falls below the Th18 thermostat setting.

For safety reasons, if the water temperature exceeds the Th21 thermostat setting, Pump P1 remains active at all times.

Water Recirculation

When there is domestic hot water demand and the boiler water temperature exceeds the Th19 thermostat setting, or when the boiler water temperature exceeds the Th20 thermostat setting, pump P2 activates.

If the water temperature exceeds the Th21 thermostat setting, pump P2 is deactivated.

Example: Th18 = 5 °C, Th19 = 40 °C, Th20 = 30 °C, Th21 = 70 °C

Water temperature	Flow regulator	Model	Operating mode	Pump P2	Pump P1
$T < 5^{\circ}\text{C}$	-	-	-	OFF	ON
$5^{\circ}\text{C} \leq T < 30^{\circ}\text{C}$	-	-	-	OFF	OFF
$30^{\circ}\text{C} \leq T < 40^{\circ}\text{C}$	-	-	-	ON	OFF
$40^{\circ}\text{C} \leq T < 70^{\circ}\text{C}$	Open	Winter	Pellet	OFF	ON
		Summer	Pellet	OFF	OFF
	Closed	-	Wood	OFF	ON
		-	-	ON	OFF
$T \geq 70^{\circ}\text{C}$	-	-	-	OFF	ON

Configuration 2

By setting parameter **P26=2**, the configuration shown in Figure 5 is selected:

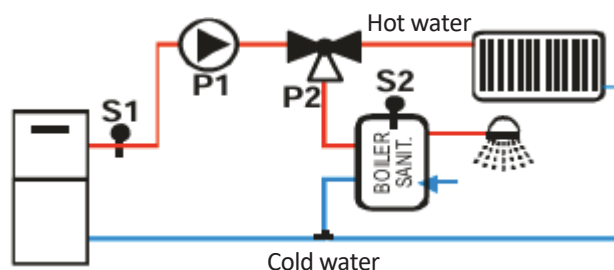

Fig.5

Heating

Pump P1 activates if the boiler water temperature exceeds the Th20 thermostat setting and the temperature difference between probe S1 and probe S2 is greater than the Th57 thermostat setting. The pump also activates if the boiler water temperature exceeds the Th19 thermostat setting. To prevent water freezing, the pump activates if the water temperature falls below the Th18 thermostat setting. For safety reasons, if the water temperature exceeds the Th21 thermostat setting, pump remains active at all times.

Domestic Hot Water (DHW)

The valve directs water to the DHW tank if the water temperature does not exceed the DHW/buffer tank thermostat setting and the boiler water temperature exceeds the Th20 thermostat setting.

For safety reasons, if the boiler water temperature exceeds the Th21 thermostat setting, the valve directs water to the system.

Example: Th18 = 5 °C, Th19 = 65 °C, Th20 = 50 °C, Th21 = 70 °C, Th57 = 5 °C, DHW/Buffer Tank Thermostat = 55 °C

Configuration 3

By setting parameter **P26=3**, the configuration shown in Figure 6 is selected.

Probe S1 T.	Probe S2 T.	Model	Operating mode	Difference	Valve P2	Pump P1
$T < 5^{\circ}\text{C}$	-	-	-	-	system (OFF)	ON
$5^{\circ}\text{C} \leq T < 50^{\circ}\text{C}$	$T > 55^{\circ}\text{C}$	Winter	-	-	system (OFF)	OFF
	$T < 55^{\circ}\text{C}$	Winter	-	-	recirculation (ON)	OFF
$50^{\circ}\text{C} \leq T < 65^{\circ}\text{C}$	$T < 55^{\circ}\text{C}$	Summer	-	-	recirculation (ON)	OFF
		-	-	$< 5^{\circ}\text{C}$	recirculation (ON)	OFF
	-	-	$\geq 5^{\circ}\text{C}$	recirculation (ON)	ON	
	$T > 55^{\circ}\text{C}$	Winter	-	-	system (OFF)	OFF
		Summer	-	$< 5^{\circ}\text{C}$	recirculation (ON)	OFF
		Summer	-	$\geq 5^{\circ}\text{C}$	recirculation (ON)	ON
$65^{\circ}\text{C} \leq T < 70^{\circ}\text{C}$	$T < 55^{\circ}\text{C}$	-	-	$< 5^{\circ}\text{C}$	recirculation (ON)	OFF
		-	-	$\geq 5^{\circ}\text{C}$	recirculation (ON)	ON
	$T > 55^{\circ}\text{C}$	Winter	Wood	-	system (OFF)	ON
		Summer	Wood	-	recirculation (ON)	ON
		Winter	Pellet	-	system (OFF)	ON
		Summer	Pellet	$< 5^{\circ}\text{C}$	recirculation (ON)	OFF
Summer	Pellet	$\geq 5^{\circ}\text{C}$	recirculation (ON)	ON		
$T \geq 70^{\circ}\text{C}$	-	-	-	-	system (OFF)	ON

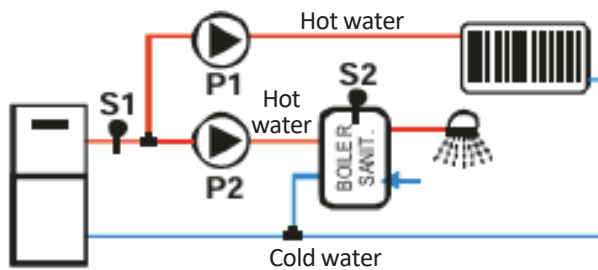

Fig. 6

Heating

Pump P1 activates above the Th19 thermostat setting if the temperature difference detected by probes S1 and S2 is lower than the Th57 thermostat setting. To prevent water freezing, the pump also activates if the water temperature falls below the Th18 thermostat setting or exceeds the Th21 thermostat setting.

Domestic Hot Water (DHW)

Pump P2 is responsible for heating the water in the DHW tank. It activates only if the boiler water temperature exceeds the Th20 thermostat setting and the temperature difference detected by probes S1 and S2 is greater than the Th57 thermostat setting.

For safety reasons, if the boiler water temperature exceeds the Th21 thermostat setting, Pump P2 deactivates.

Example: Th18 = 5 °C, Th19 = 65 °C, Th20 = 50 °C, Th21 = 70 °C, Th57 = 5 °C, DHW thermostat/buffer tank = 55 °C

Probe S1 T.	Probe S2 T.	Model	Operating mode	Difference	Pump P2	Pump P1
$T < 5^{\circ}\text{C}$	-	-	-	-	OFF	ON
$5^{\circ}\text{C} \leq T < 50^{\circ}\text{C}$	-	-	-	-	OFF	OFF
$50^{\circ}\text{C} \leq T < 65^{\circ}\text{C}$	$T < 55^{\circ}\text{C}$	-	-	$< 5^{\circ}\text{C}$	OFF	OFF
		-	-	$\geq 5^{\circ}\text{C}$		OFF
	$T > 55^{\circ}\text{C}$	-	-	$< 5^{\circ}\text{C}$	OFF	OFF
		Winter	-	$\geq 5^{\circ}\text{C}$	OFF	OFF
		Summer	-	$\geq 5^{\circ}\text{C}$	ON	OFF
$65^{\circ}\text{C} \leq T < 70^{\circ}\text{C}$	$T < 55^{\circ}\text{C}$	-	-	$< 5^{\circ}\text{C}$	OFF	OFF
		-	-	$\geq 5^{\circ}\text{C}$	ON	OFF
	$T > 55^{\circ}\text{C}$	-	Wood	-	OFF	ON
		Winter	Pellet	-	OFF	ON
		Summer	Pellet	$< 5^{\circ}\text{C}$	OFF	OFF
		Summer	Pellet	$\geq 5^{\circ}\text{C}$	ON	OFF
$T \geq 70^{\circ}\text{C}$	-	-	-	-	OFF	ON

Configuration 4

By setting parameter **P26=4**, the configuration shown in Figure 7 is selected:

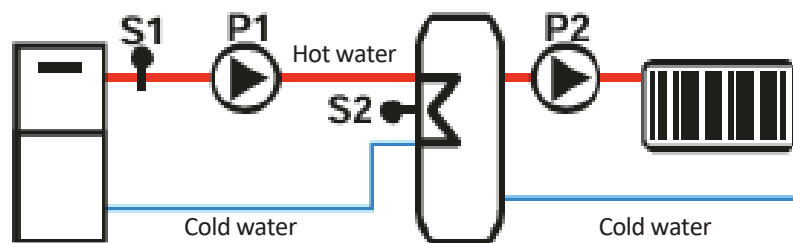

Fig. 7

Buffer tank loading

If the boiler temperature exceeds the pump activation thermostat Th19, the system heats the water in the buffer tank provided there is a temperature difference between the two probes (boiler temperature minus buffer tank temperature greater than the Th57 differential thermostat). For safety reasons, if the boiler water temperature exceeds the Th21 thermostat setting, pump P1 activates.

Pump P2 activates above the Th59 thermostat setting.

Example: Th18 = 5 °C, Th19 = 40 °C, Th21 = 70 °C, Th57 = 5 °C, Th59 = 50 °C

Probe S1 T.	Difference		Pump P2
$T < 5^{\circ}\text{C}$	-		ON
$T < 40^{\circ}\text{C}$	-		OFF
$T \geq 40^{\circ}\text{C}$	$< 5^{\circ}\text{C}$		OFF
	$\geq 5^{\circ}\text{C}$		ON
$T \geq 70^{\circ}\text{C}$	-		ON
Probe S2 T.	Model	Operating mode	Pump P1
$T < 50^{\circ}\text{C}$	-	-	OFF
$T \geq 50^{\circ}\text{C}$	Winter	-	ON
	Summer	Wood	ON
	Summer	Pellet	OFF

Configuration 5

By setting parameter **P26=5**, the configuration shown in Figure 8 is selected:

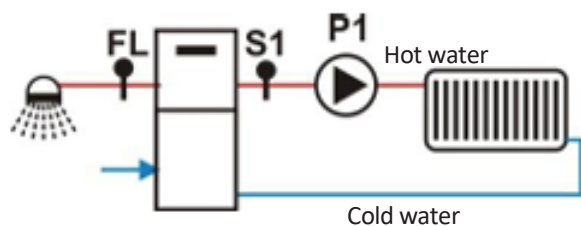

Fig. 8

Heating

The pump activates above the Th19 pump activation thermostat setting.

To prevent water freezing, the pump also activates if the water temperature falls below the Th18 thermostat setting. For safety reasons, if the water temperature exceeds the Th21 thermostat setting, pump remains active at all times.

Domestic Hot Water (DHW)

When there is a domestic hot water demand, the system blocks the pump.

Example: Th18 = 5 °C, Th19 = 40 °C, Th21 = 70 °C

Water temperature	Model	Flow regulator	Pump
$T < 5^{\circ}\text{C}$	-	-	ON
$5^{\circ}\text{C} < T < 40^{\circ}\text{C}$	-	-	OFF
$40^{\circ}\text{C} < T < 70^{\circ}\text{C}$	Summer	-	OFF
	Winter	Closed	OFF
	Winter	Open	ON
$T > 70^{\circ}\text{C}$	-	-	ON

Configuration 6

By setting parameter **P26=6**, the configuration shown in Figure 9 is selected

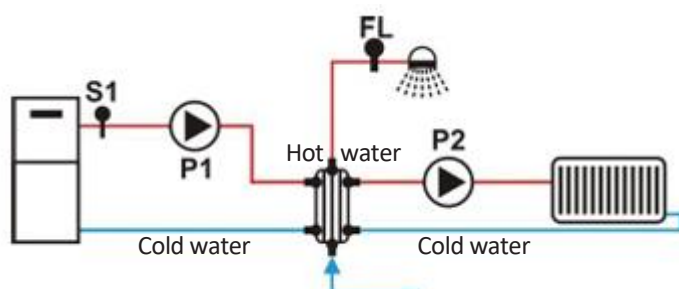

Fig. 9

Heating

Pump P2 activates above the Th19 thermostat setting if there is no domestic hot water demand. To prevent water freezing, Pump P2 also activates if the water temperature falls below the Th18 thermostat setting or rises above the Th21 thermostat setting.

Domestic Hot Water (DHW)

Pump P1 activates above the Th20 thermostat setting. To prevent water freezing, Pump P2 activates if the water temperature falls below the Th18 thermostat setting.

Example: Th18 = 5 °C, Th19 = 40 °C, Th20 = 30 °C, Th21 = 70 °C

Probe S1 T.	Flow regulator	Model	Operating mode	Pump P2	Pump P1
T < 5°C	-	-	-	ON	ON
5°C ≤ T < 30°C	-	-	-	OFF	OFF
30°C ≤ T < 40°C	-	-	-	ON	OFF
40°C ≤ T < 70°C	Closed	-	-	ON	OFF
	Open	Winter	-	ON	ON
		Summer	Wood	ON	OFF
		Summer	Pellet	ON	OFF
T ≥ 70°C	-	-	-	ON	ON

6.2. Domestic Hot Water (DHW) function

In hydraulic systems with a flow regulator or DHW buffer tank, if there is a domestic hot water demand, the DHW function activates and the boiler thermostat is set to the Th21-Ih21 thermostat value. When there is no longer a demand, the function ends after the T68 timer expires.

7. Operating States (Functions)

7.1 Blocked (Block)

To exit the blocked state, press the unlock button (P2) for 3 seconds; if the blocking conditions no longer exist, the system switches off.

Parameters	Status control	Fan	Reducer	Heater
	flue gas t. > Th01	V11	OFF	OFF
	flue gas t. < Th01	OFF	OFF	OFF

7.2 Off Mode

Parameters	Status control		Fan	Reducer	Heater
	flue gas t. > Th01	→ switches to shutdown mode if the system was previously in pellet mode	OFF	OFF	OFF
	Water temperature > Th25	→ switches to Blocked			

7.3 Check up

Parameters	Status control		Fan	Reducer	Heater
T01	flue gas t. > Th09 and the system was previously in pellet mode	→ switches to operating mode	Maximum speed	OFF	OFF
	flue gas t. > T01 and T11 and the system was previously in wood or combined mode	→ switches to recovery ignition			
	Check after expiry of T01	→ switches to ignition			

7.4 Ignition

* Preheating

Parameters	Status control		Fan	Reducer	Heater
T02	flue gas t. > Th09	→ switches to operating mode	V24	OFF	ON

* Preloading

Parameters	Status control		Fan	Reducer	Heater
T03	flue gas t. > Th09	→ switches to operating mode	V01	ON	ON
T29				OFF	

* Fixed ignition phase

Throughout this phase, the minimum flue gas temperature is maintained.					
Parameters	Status control		Fan	Reducer	Heater
T04	flue gas t. > Th09	→ switches to operating mode	V01	C01	ON

* Variable ignition phase

Throughout this phase, the minimum flue gas temperature is maintained.					
Parameters	Status control		Fan	Reducer	Heater
	flue gas t. > Th09	→ switches to operating mode			

T05	flue gas t. > Th06 and flue gas t. > from minimum stored value +D41	→ switches to stabilization	I ignition: V01	I ignition: C01	ON
Check after expiry of T05	flue gas t. < Th06 or flue gas t. < from the minimum stored value +D41	→ switches to re-ignition from the variable phase	II ignition: V10	II ignition: C10	
		→ switches to shutdown with error Er12 if the permitted number of attempts has been reached			

** Stabilization*

Parameters	Status control		Fan	Reducer	Heater
T06	flue gas t. > Th09	→ switches to operating mode	V02	C02	ON if the flue gas temperature is below < Th02 otherwise OFF
	flue gas t. < Th06	→ switches to re-ignition from the variable phase			
		→ switches to shutdown with error Er12 if the permitted number of attempts has been reached			
Check after expiry of T06	flue gas t. > Th06+D01	→ switches to operating mode			
		→ switches to re-ignition from the variable phase			
	flue gas t. < Th06+D01	→ switches to shutdown with error Er12 if the permitted number of attempts has been reached			

** Recovery ignition*

*If the system switches to re-ignition due to the flue gas temperature exceeding **Th11**, the reference thermostat for the re-ignition attempt phases is no longer **Th01**, but **Th11**.*

Parameters	Status control		Fan	Reducer	Heater
T13	flue gas t. > Th01	→ timer T13 starts	V09	OFF	OFF
Check after expiry of T13	flue gas t. > Th01	→ wait			

** Burner cleaning*

Parameters	Status control	Fan	Reducer	Heater
	This phase, performed at the end of the standby phase, is present only if the output is configured as Burner Cleaning, and it ends when the motor stops.	OFF	OFF	OFF

** Final cleaning*

Parameters	Status control	Fan	Reducer	Heater	
T16	flue gas t. < Th01	→ Final cleaning timer T16 starts	Maximum	OFF	OFF

Check after expiry of T16	flue gas t. < Th01	→ switches to check	speed		
----------------------------------	---------------------------	---------------------	-------	--	--

7.5 Run mode

Parameters	Status control		Fan	Reducer	Heater
T14	flue gas t. < Th03 or flue gas t. < Shutdown thermostat for the power level in use	→ T14 timer starts Shutdown standby begins	User power	User power	OFF
Check after expiry of T14	→ switches to shutdown with error Er03				
	flue gas t. > Th07	→ switches to modulation			
	water t. > Boiler thermostat				
A01=1 , not Air system	Room temperature > Room thermostat*	→ switches to standby			
A01=2 or 4 not Air system	Room temperature > Room thermostat*				
P26=2, 3	DHW temperature > DHW/buffer tank thermostat and summer mode				
P26=4	buffer tank t. > DHW/Buffer Tank Thermostat				
P26=0 A45=1	In summer mode, if there is no demand for hot water				
	Water T > Th25	→ switches to safety			

**In a hydraulic system, this condition applies if there is no domestic hot water demand or if a hydraulic system with a buffer tank is selected.*

*If the system has just completed ignition, the shutdown thermostats and **Th03** thermostat are measured at the end of **T14+T00**.*

7.6 Modulation

Parameters	Status control		Fan	Reducer	Heater
T14	flue gas t. < Th03 or flue gas t. < Shutdown thermostat for the power level in use	→ T14 timer Shutdown standby begins	V11	C11	OFF
Check after expiry of T14	→ switches to shutdown with error Er03				
A01=2 or 4	Room temperature > Room thermostat*				
A13=1	If during T43 time and water t > Boiler thermostat +D23				
A13=2	If during T43 time and summer mode and water t > Boiler thermostat +D23				
	DHW temperature >	→ switches to			

P26=2, 3	DHW/buffer tank thermostat and summer mode	standby Standby			
P26=4	buffer tank t. > DHW / buffer tank thermostat				
P26=0 A45=1	In summer mode, if there is no demand for hot water				
	flue gas t. > Th08	→ switches to Safety			
	water temperature > Th25				

**In a hydraulic system, this condition applies if there is no domestic hot water demand or if a hydraulic system with a buffer tank is selected. If the system has just completed ignition, the shutdown thermostats and Th03 thermostat are measured at the end of T14+T00.*

7.7 Standby

When the conditions that caused the system to enter Standby are no longer met, the **T11** timer starts.

After it expires, the system switches to Check Mode. If the flue gas temperature > **Thermostat Th08** (only if the system allows the use of thermocouple in pellet mode), water temperature > **Thermostat Th25** or air temperature > **Thermostat Th25**, the system switches to Safety. Depending on the value of parameter **A27**, the burner can be kept running or turned off and cleaned.

7.8 Safety

Parameters	Status control		Fan	Reducer	Heater
T15	flue gas t < Th08 and water t < Th25 and air T < Th25	→ switches to previous state	V12 if the system was previously in Standby, V11 if it was in Modulation	OFF	OFF
Check after expiry of T15	→ switches to shutdown with error Er05 or Er04				

7.9 Shutdown

Parameters	Status control		Fan	Reducer	Heater
T13	flue gas t. > Th01	→ timer T13 starts	V09	OFF	OFF
Check after expiry of T13	flue gas t. > Th01	→ wait			

8. Final cleaning

Parameters	Status control		Fan	Reducer	Heater
T16	flue gas t. < Th01	→ timer T16 starts	Maximum speed	OFF	OFF
Check after expiry of T16	→ switches to OFF without error, otherwise switches to Blocked		OFF		

8.1 Combustion Power Selection

Automatic Mode

When setting the operating power, the user can select Automatic [A] or Manual [M] mode. If Automatic mode is selected, the power is automatically chosen according to the main temperature and the set value of the main thermostat.

If:

- * main temperature \leq main thermostat **-D08** → system operates at maximum power
- * main thermostat **-D08** < main temperature < main thermostat → combustion power is selected proportionately
(the greater the difference between the water temperature and the thermostat value, the higher the selected power)
- * Main Temperature \geq Main Thermostat → system operates at Power 1 or, if enabled, at modulation power

Example: System=Hydraulic, Mode=[A], Boiler thermostat =60°C, D08 =20 °C, P03 =5						
Water temperature °C	≤ 40	40 ÷ 45	46 ÷ 50	51 ÷ 55	56 ÷ 60	≥ 60
Combustion power	5	4	3	2	1	1 or Mod.

8.2 Reducer calibration

The user adjusts the pellet feed time/speed in steps from -7 to 7.

P15 represents the percentage value of a single step and is applied to the default operating power values. The calculated values are adjusted to remain within the configured range **P27 ÷ P05**.

Example	P15 =10%	C03 =2.0	C04 =3.0	C05 =4.0	C06 =5.0	C07 =6.0	C11 =1.0
	Step = --1	C03 =1.8	C04 =2.7	C05 =3.6	C06 =4.5	C07 =5.4	C11 =0.9

8.3 Fan calibration

The user adjusts the combustion fan speed in steps from -7 to 7. P16 represents the percentage value of a single step, which is applied to the default operating speeds. The calculated values are adjusted to remain within the configured range P14 ÷ P30.

Example	P16=5%	V03=1000	V04=1200	V05=1400	V06=1600	C07=6.0	V11=900
	Step = -+3	V03=1150	V04=1380	V05=1610	V06=1840	C07=5.4	V11=1035

9. Room thermostat

Depending on the value of parameter A01, the following occurs:

* **A01=0**

Open contact: the system switches to shutdown mode.

Closed contact: the system switches to ignition.

* **A01=1**

Closed contact: the system switches to operating mode.

Open contact: the system switches to modulation mode.

* **A01=2**

Closed contact: the system switches to operating mode.

Open contact: system switches to standby.

* **A01=3**

Closed contact: system activates the pump.

Open contact: if the water temperature exceeds the system pump activation thermostat(Th19 or Th59), the system blocks the system pump until the temperature reaches Th21 or Th78 (if P26=4).

* **A01=4**

Closed contact: the system restarts the pump and switches to operating mode.

Open contact: the system switches to Standby and blocks the system pump as in case 3.

10. DHW/buffer tank probe

Enable one of the configurable inputs as a DHW/buffer tank probe if a hydraulic system that includes it is selected (P26=2, 3, 4).

11. Solenoid valve/pump P2

The output controls a two-wire valve or a non-high-efficiency pump if a triac output is selected. When using a 2–3-way module that switches the output from the triac to a changeover relay, it is possible to connect a three-way solenoid valve or a high-efficiency pump. The operation of the connected device depends on the selected hydraulic system.

11.1 Pump P1

The output controls a non-high-efficiency pump if a triac output is selected. When using a 2–3-way module that switches the output from the triac to a changeover relay, it is possible to connect a high-efficiency pump. The operation of the connected device depends on the selected hydraulic system.

12.0 Shutdown during ignition phase

When the system has completed the preheating ignition phase and is turned off by an external device (such as an internal or external chrono), it completes ignition and stabilization, and when fully operational, it switches to shutdown. The display shows the message “Ignition Blocked”.

*If an error occurs, the system immediately switches to shutdown with error. **By pressing the ignition button, it is possible to perform an immediate shutdown or restart ignition.***

13.0 Mains power failure

*In the event of a mains power failure, the system preserves the most important operational data. When mains power is restored, the system evaluates the saved data and, if the data recovery is correct, the following occurs based on the value of parameter **A53**:*

** Status recovery mode 0 (**A53**=0)*

- If the mains power outage lasted less than **T88**, the system returns to the previous state.*
- If the system was on and the mains power outage occurred between **T88** and **T89**, the system switches to Recovery Ignition.*
- If the mains power outage lasted longer than **T89**, the system switches to Block Mode with error **Er15**.*

14.0 User manual

The Elegant pellet boiler is designed for burning wood pellets. The product is manufactured using state-of-the-art technology from high-quality, certified materials, welded with modern robotic technology, and tested according to EN 14785:2006 to meet all requirements for connection to a central heating system, as well as European standards regarding efficiency and harmful particle emissions.

- * During installation, all national, European, and local regulations must be observed.
- * Only original spare parts may be used, available through an authorized dealer, service centre, or directly from the manufacturer.
- * The boiler must not be operated in a flammable or explosive atmosphere. The product must not be used by children or persons with reduced physical or mental capabilities, or by persons lacking the necessary knowledge and experience, unless supervised or trained by someone responsible for their safety. Children must be supervised when near the appliance.

14.1 Connecting the Boiler to the Flue

A correctly sized and installed flue is a prerequisite for the safe operation of the boiler and heating efficiency. The flue must be well thermally insulated. Cleaning doors must be installed at the lower part of the flue. The flue must be resistant to flue gas condensation.



WARNING:

- * The horizontal section of the flue pipe must have a minimum slope of 3%.
- * The length of the horizontal section of the flue pipe must be minimal and in any case no longer than 3 m.
- * The number of changes in direction of the flue pipe, including “T” elements, must not exceed 3.

14.2 Fuel

The pellets used should meet the following standards: EN Plus, DIN Plus, ONorm-M-7135 or DIN 51731.

* Pellet characteristics

Moisture content ----- 6 – 8%

Diameter ----- 6mm

Length----- 10 – 30mm

Ash content ----- 1%

14.3 Boiler installation

Minimum clearances of the boiler from walls and other objects:

A – 500mm

B – 150mm

C – 300mm

D – 500mm

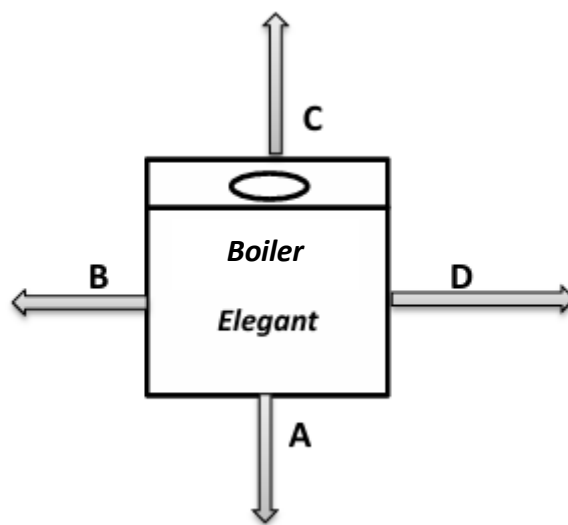

Fresh air supply opening:

The room where the boiler is installed must have a fresh air supply opening sized according to the boiler's power. The opening must be protected with a protective mesh or grille. All installation work must be carried out in compliance with applicable national and European standards. The boiler must not operate in a flammable or explosive environment.

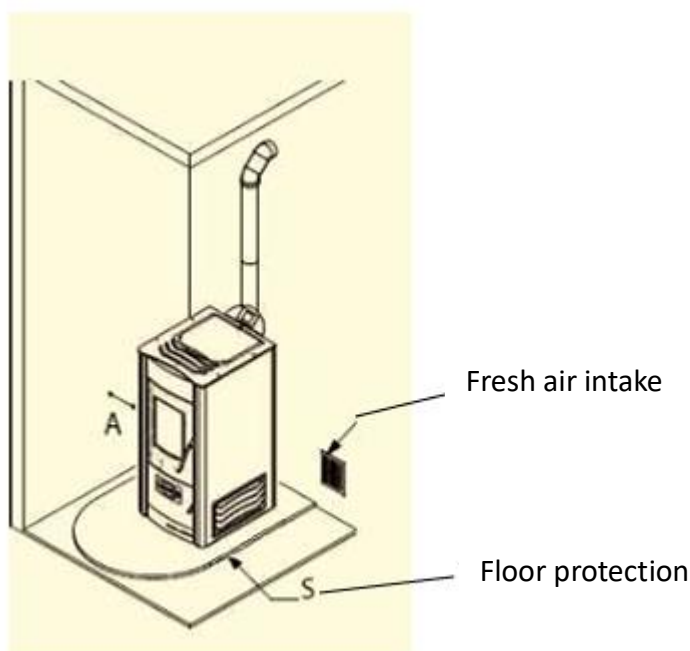

14.4 First Boiler Start-Up

* The Elegant pellet boiler is factory-equipped with a circulation pump, expansion vessel, safety valve, and automatic air vent. Connection of the boiler to the central heating system is done via the supply and return pipes.

* *The control board is set to Hydraulic System 5. If the hydraulic system is changed, follow this manual to configure the selected system (DHW/buffer sensor, pump P1, P2, solenoid valve, etc.).*

* **Before the first boiler start-up, check the following:**

- Remove accessories from the boiler (user manual, power cable).
- Connect the boiler to the piping system and fill it with water.
- Unscrew the cap on the automatic air vent located under the boiler cover.
- Connect the flue outlet to the flue.
- Check that the doors are properly closed and the ash pan is correctly positioned.

- Ensure the flame guide* is correctly installed.
- Fill the hopper with pellets.
- Connect the power cable to the mains (220 V) and switch on using the main switch located on the rear of the boiler.
- Fill the auger conveyor with pellets as follows (the hopper must contain pellets):

1. Press the SET button.
2. Select the LOAD option.
3. Confirm by pressing SET.
4. Select ON and confirm with SET.
5. Monitor the pellets entering the burner through the firebox door until the burner is filled, then switch the function to OFF.
6. Empty any pellets remaining in the burner before starting the boiler, ensuring the burner is correctly positioned.

NOTE:

This function is only used during the first start-up or when the hopper is completely empty (no pellets in the auger conveyor).

7. Start the boiler by pressing and holding button P2 for 5–6 seconds.

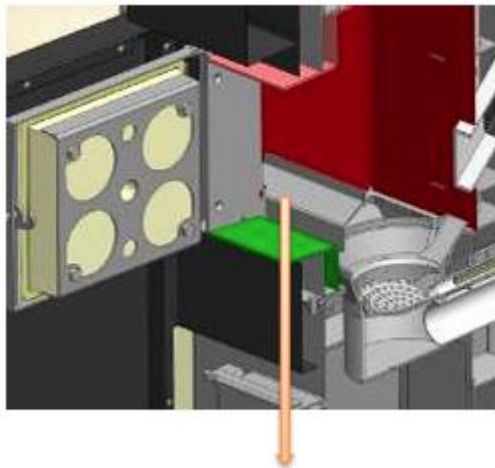

Flame guide*

15.0 Boiler Cleaning and Maintenance

***General information.**

The boiler must be switched off and completely cooled before performing any cleaning or maintenance activities.

Cleaning and maintenance intervals primarily depend on the quality of the pellets used. Wet pellets contain a high percentage of ash, dust, and unburned residues, which can double the required cleaning and maintenance intervals. It is strongly recommended to use only certified and tested pellets.

There are three cleaning categories: **Daily, Weekly and Monthly**

***Daily cleaning**

Depending on the quality of the pellets, the burner should be cleaned once a day. For uninterrupted operation, all burner openings must be clear and clean.

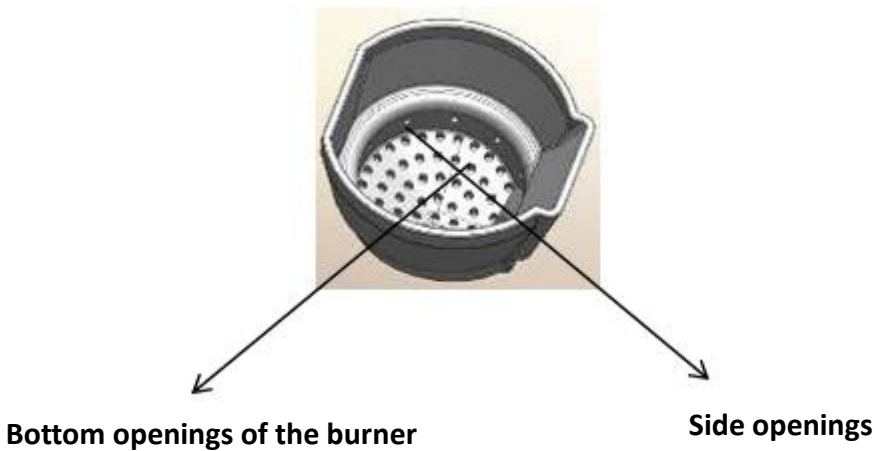

The ash pan should be emptied daily, or less frequently depending on the intensity of boiler operation.

To ensure efficient energy transfer to the water, cleaning should be performed at least daily. The levers are operated using the turbulator cleaning tool. Pull the turbulator levers up and down 3–4 times and move the turbulator shaker lever forward and backward for the Elegant 37 kW model.

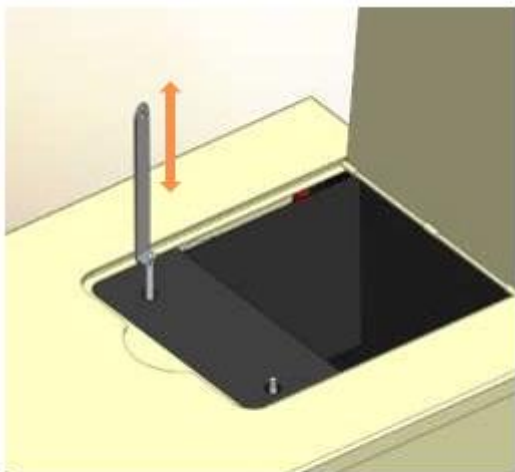

ELEGANT 27kw

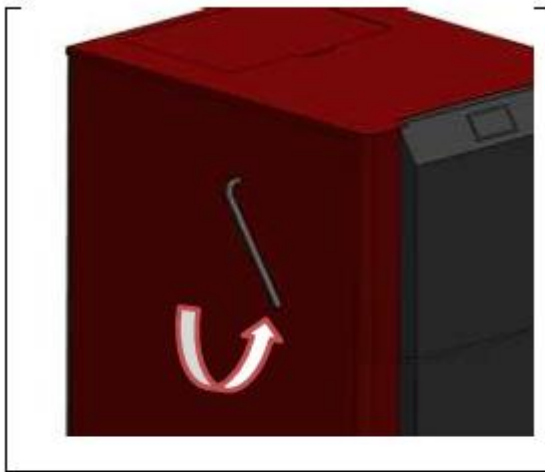

ELEGANT 37kw

* Weekly cleaning

- Clean the firebox and burner housing from ash
- It is recommended to vacuum dust and ash from the firebox at least twice a week using a suitable vacuum cleaner

* Monthly cleaning



NOTE:

The boiler must be completely cooled before cleaning

- Clean the flue channel every two months, or more often depending on the boiler operating mode and pellet quality.

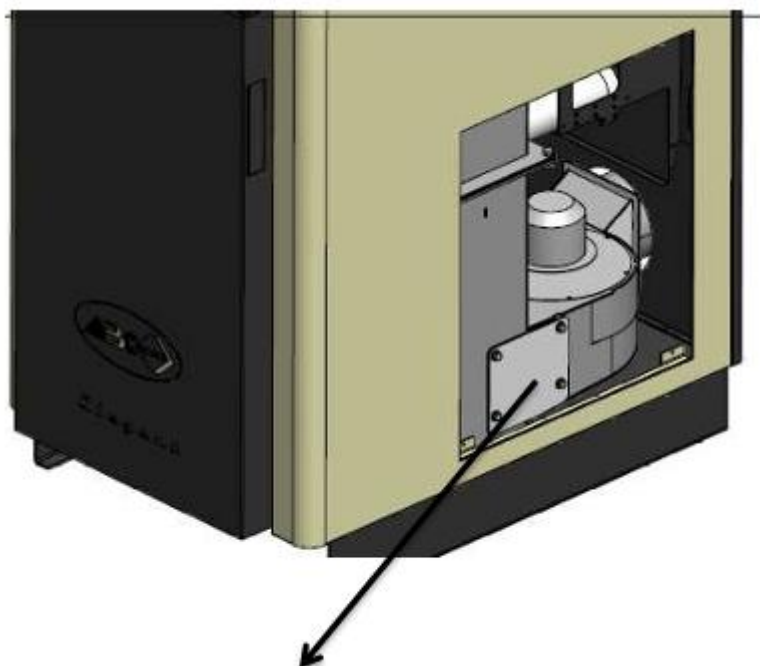

Cleaning opening cover

- Remove ash deposits from the left and right combustion chambers using a vacuum cleaner
- Replace the cleaning hatch cover and tighten all four screws

To guarantee safety and reliable operation, the following tasks must be performed at the end of each season or more frequently if necessary:

- Gaskets ensure proper boiler operation only when undamaged and correctly installed.
- Gaskets must be periodically checked. If worn or damaged, they must be replaced immediately.

- Flue pipes must be cleaned and vacuumed once per season, or more often if necessary. If horizontal sections exist, remove ash residues to prevent obstruction of flue gas flow.

***Pellet hopper cleaning**

Do not refill the hopper without first vacuuming any residual pellets (dust, small fragments, etc.) from the previous supply.

***Pipe heat exchanger cleaning**

Depending on the intensity of boiler operation, clean the pipe heat exchangers every two months (or more frequently if necessary) following the procedure shown in the diagram:

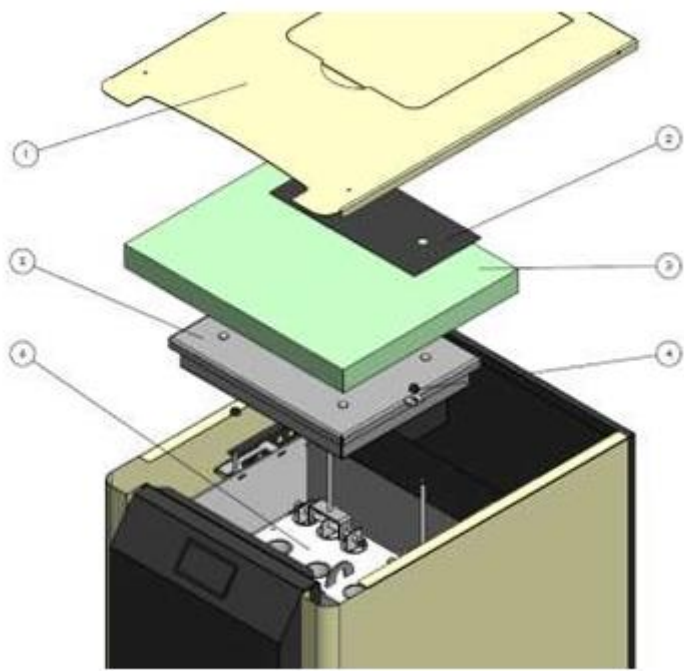

- 1 – Boiler lid
- 2 – Turbulator flange
- 3 – Insulation
- 4 – Lid screws (2 pcs)
- 5 – Cover
- 6 – Areas to be cleaned of ash

After cleaning, reassemble all components in the reverse order of disassembly.

16.0 Operational Interruptions and Troubleshooting

Issue	Possible cause	Troubleshooting
-------	----------------	-----------------

<i>Pellets do not reach the burner (Err 03; Err 12)</i>	<ul style="list-style-type: none"> - No pellets in the hopper - Blocked auge - Auger motor 	<ul style="list-style-type: none"> - Refill the hopper with pellets - Empty the hopper and unblock the auger - Replace the auger motor
<i>Flame gradually dies out until complete shutdown (Err 03; Err 02)</i>	<ul style="list-style-type: none"> - No pellets in the hopper - Firebox door not closed - Poor quality pellets - Burner not cleaned - Blocked flue pipes - Pressure switch fault - Fan fault 	<ul style="list-style-type: none"> - Refill the hopper with pellets - Close doors or replace gaskets - Use certified pellets - Ensure all burner openings are clear - Clean flue pipes - Replace pressure switch - Check fan and condenser operation and replace if necessary
<i>Pellet accumulation in burner / weak flame Err 03</i>	<ul style="list-style-type: none"> - Insufficient combustion air - Wet pellets - Fan malfunction - Th01 higher than Th06 	<ul style="list-style-type: none"> - Clean the burner ensuring all openings are clear - Check air supply pipe - Use certified pellets - Inspect fan and replace if necessary
<i>Ignition failure Err 12; Err 02</i>	<ul style="list-style-type: none"> - Power outage - Pressure switch failure (Err 02) - Blocked fan housing or flue channel - Heater burnout 	<ul style="list-style-type: none"> - Ensure main switch is in "I" - Replace pressure switch - Clean fan housing and flue channels - Check the heater and replace if necessary

*** Information regarding dismantling and disposal of the boiler**

Dismantling and disposal of the (used or old) stove/boiler is the sole responsibility of the boiler owner. The owner must comply with applicable legal regulations in their country regarding safety and environmental protection. Dismantling and disposal can be entrusted to a third party, provided that the company is authorised to collect and dispose of such materials.



CAUTION!

Discarding the stove in public areas poses a serious risk to people and animals. In such cases, the owner is always responsible for any injuries to persons or animals.

17. Appendix



Statement of conformity:

Manufacturer: „ABC PROIZVOD“ doo

Miloša Obrenovića 2

31000 Užice/ Serbia

Declares that the pellet heating appliance named

***Elegant** is compliant with the CE (Construction Products Directive) EU 305/2011, and meets the following harmonised standard:*

EN 303-5/2012

The company ABC PROIZVOD d.o.o., Užice, implemented the following quality management system in 2007:

SRPS ISO 9001/ 2015, which is dully maintained and continuously improved.



18. Installation Instructions for the Additional Pellet Hopper

The ELEGANT 27 kW boiler can be upgraded with an additional pellet hopper, increasing the total capacity to 100 kg of pellets.

Procedure for installing the additional hopper:

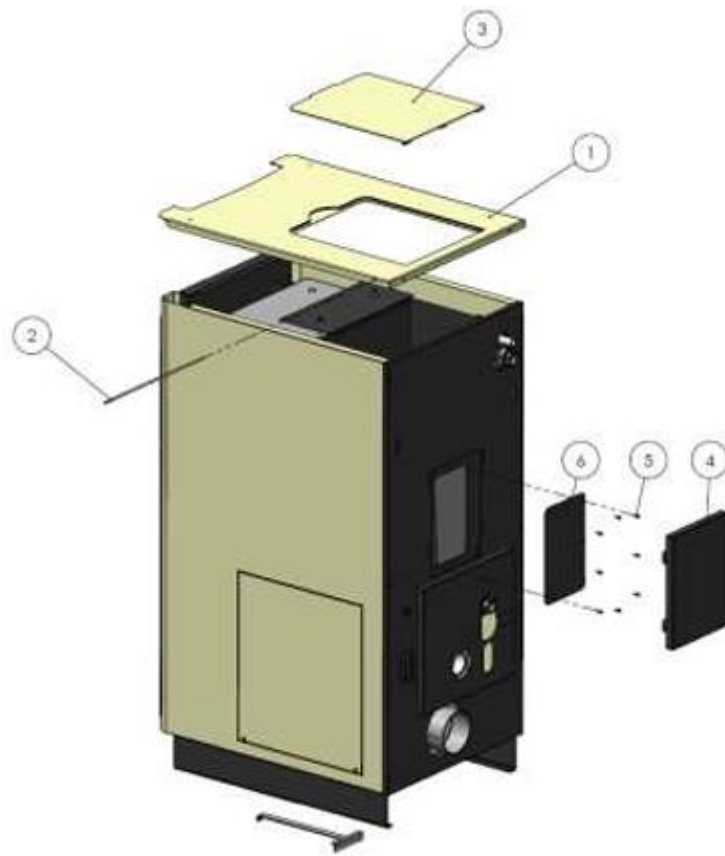

Fig. 1

Lift the boiler lid (1).

Remove the hinge pin of the lid door (2).

Remove the lid door (3).

Replace the lid on the boiler without the door.

Remove the top cover of the rear panel (4) by lifting it upwards and pulling towards yourself.

Unscrew the eight screws (5) securing the pellet hopper cover (6).

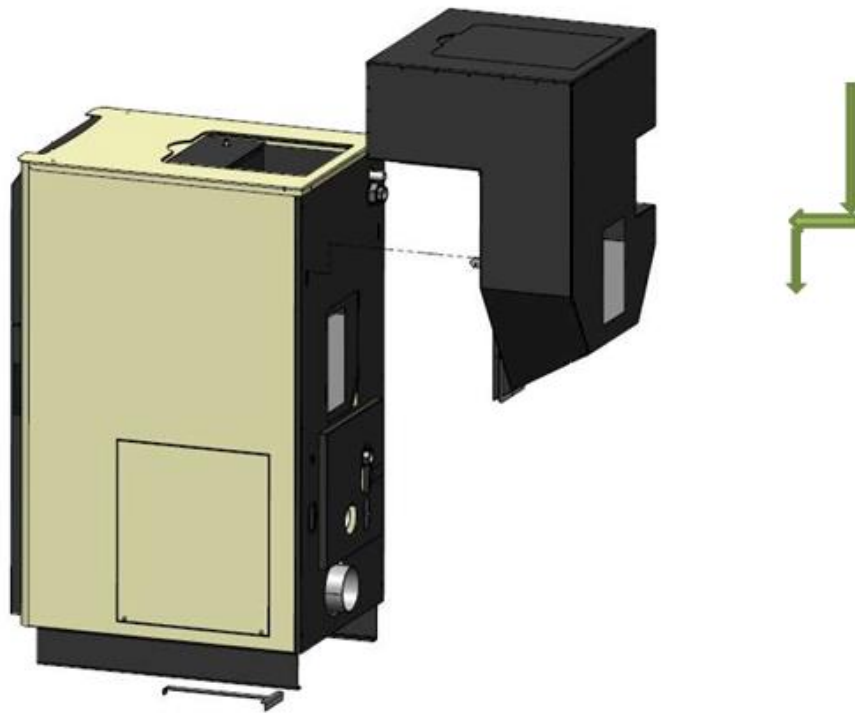

Fig. 2

- position the additional hopper onto the boiler.
- align the hopper so that the openings on the boiler hopper door match the openings on the additional hopper.
- align the openings on the rear of the boiler with the tabs on the additional hopper (2 tabs, left and right).
- push the additional hopper towards the boiler and downward until it is fully seated.

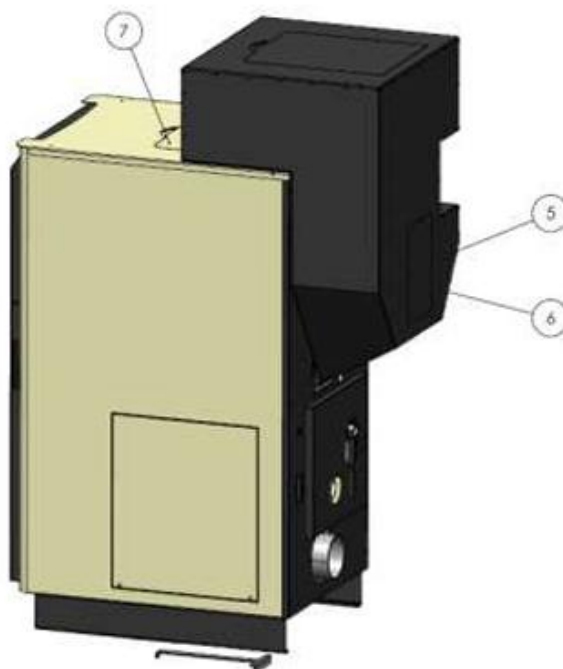

Fig. 3

- place the original pellet hopper cover (6)(Fig. 1) onto the additional hopper and secure it with the screws (5).
- Lower the turbulator lever cover (7, Fig. 3) back into position.

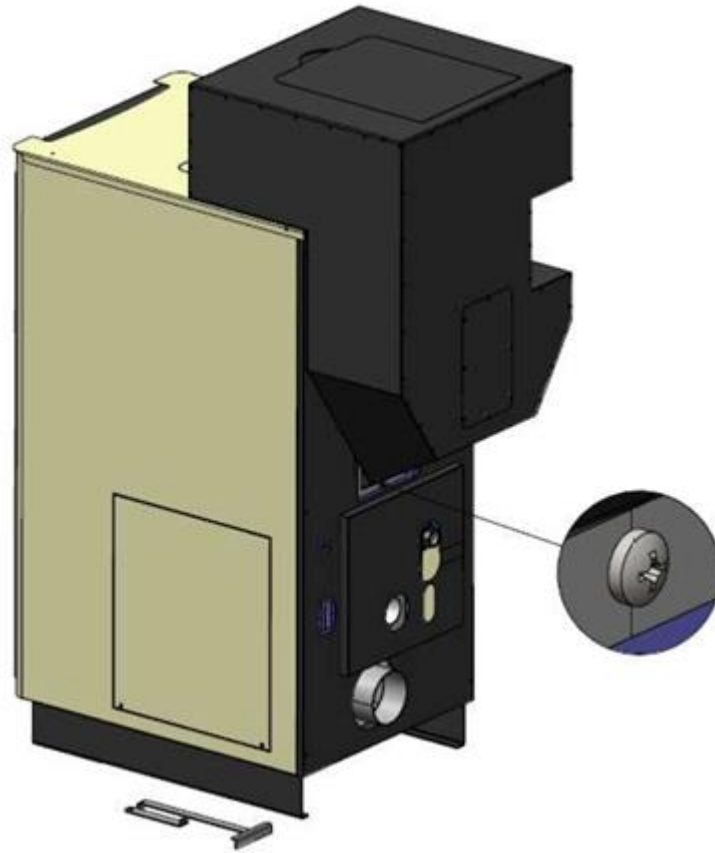
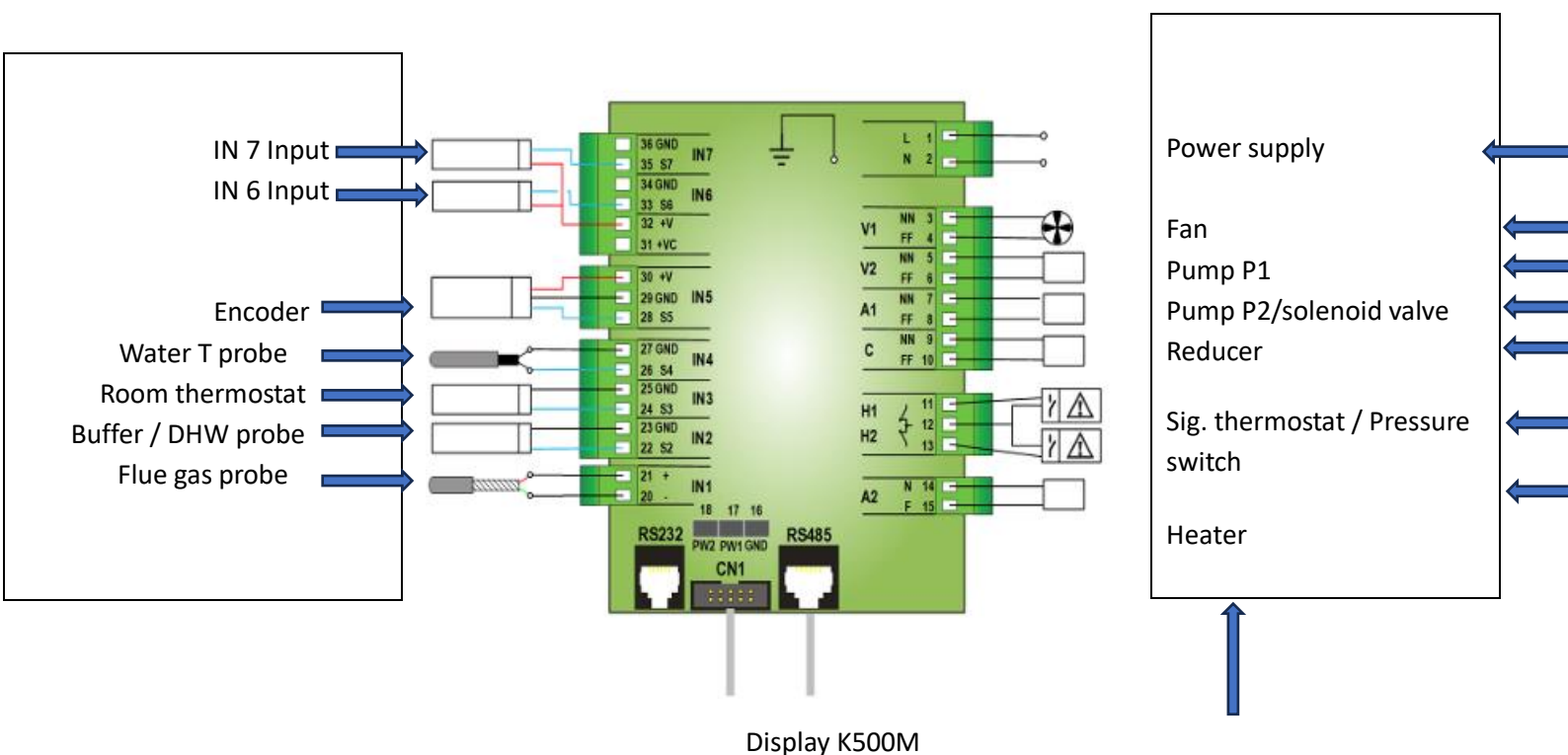

Fig. 4

- screw in the screw 4.2 × 13 mm in the position shown in Fig. 4

19. Electrical Wiring Diagram NG01



<i>Pin</i>		<i>Function</i>	<i>Technical specification</i>
1	L	Main Power Supply	230 Vac ± 10% 50/60 Hz
2	N		
3	NN	Fan	Triac control 0,9 A max
4	FF		
5	NN	Configurable Output V2 (Configuration Parameter: P44) – Pump P1	Triac control 0,9 A max
6	FF		
7	NN	Configurable Output A1 (Configuration Parameter: P52) – Pump P2 / Solenoid Valve	Triac control 1,6 A max
8	FF		
9	NN	Configurable Output C (Configuration Parameter: P28) – Reducer	Triac control 0,9 A max
10	FF		
11		Input Safety Thermostat AT1	ON/OFF contact, normally closed Jumper if unused
12			
12		Input AT2 Safety Pressure Switch	ON/OFF contact, normally closed Jumper if unused
13			
14	N	Configurable Output A2 (Configuration Parameter: P47) - Heater	Relay 3 A max
15	F		
16*	GND	Configurable Output PWM1 / DAC1 (Configuration Parameters: P140 and P142)	Signal 0-10 V, 10 mA, frequency 1 KHz
17*	PW1		
16*	GND	Configurable Output PWM2 / DAC2 (Configuration Parameters: P141 and P143)	Signal 0-10 V, 10 mA, frequency 1 KHz
18*	PW2		
20	Green-	Flue gas probe	Thermocouple K-type: 500 or 1200 °C Max
21	Red+		
22	SEG	Configurable Output IN2 (Configuration Parameter: P77)	Analogue (NTC 10K probe) / digital input
23	GND		
24	SEG	Configurable Output IN3 (Configuration Parameter: P75)	Analogue (NTC 10K probe) / digital input
25	GND		

26		Configurable Output IN4 (Configuration Parameter: P85)	Analogue/digital input
27			
28	SEG	Fan encoder sensor	TTL 0 / 5 V Signal
29	GND		
30	+V		
31	+Vc	10÷14 V	-
32	+V	+5 V	-
33	SEG	Configurable Output IN6 (configuration parameter: P78)	Analogue/digital input
34	GND		
35	SEG	Configurable Output IN7 (Configuration Parameter: P82)	Analogue/digital input
36	GND		
RS232		RS232 Connector	Programmer, KeyPro, modem, PC connection
RS485		RS485 Connector	K-series and 4Heat series control board connection
CN1		Flat cable connector	CP-series control board connection

*** Available only on boards with PWM output.**

20. CONTENTS

1. *Technical characteristics*
2. *Display: Functions and Use*
3. *Alarms*
4. *Visualisation*
5. *User Menu*
 - 5.1 *User Menu 2*
6. *Hydraulic system*
 - 6.1 *Hydraulic System Selection*
 - 6.2 *Domestic Hot Water (DHW) function*
7. *Operating States (Functions)*
 - 7.1 *Blocked (Block)*
 - 7.2 *OFF*
 - 7.3 *Check up*
 - 7.4 *Ignition*
 - 7.5 *Run Mode*
 - 7.6 *Modulation*
 - 7.7 *Stand by*
 - 7.8 *Safety Mode*
 - 7.9 *Shutdown*
8. *Final Cleaning*
 - 8.1 *Combustion Power Selection*
 - 8.2 *Reducer Calibration*
 - 8.3 *Fan Calibration*
9. *Room thermostat*

10. *DHW/buffer tank probe*
11. *Solenoid valve/pump P2*
 - 11.1 *Pump P1*
12. *Shutdown during ignition phase*
13. *Mains power failure*
14. *User manual*
 - 14.1 *Connecting the Boiler to the Flue*
 - 14.2 *Fuel*
 - 14.3 *Boiler installation*
 - 14.4 *First Boiler Start-Up*
15. *Boiler Cleaning and Maintenance*
16. *Operational Interruptions and Troubleshooting*
17. *Appendix*
18. *Installation Instructions for the Additional Hopper*
19. *Electrical Wiring Diagram*
20. *Contents*