

COMBO Pellet-fired Boiler

User Manual



1. Technical Characteristics

DESCRIPTION		UoM	25kw	40kw	60kw
Heating stove capacity		kw	25	40	60
Water content in the heating stove		l	80	100	120
Draft required		Pa	12	14	16
Electrical power:					
- during ignition phase		W	370	480	480
- during operation phase		W	70	180	180
Electrical voltage		V	230	230	230
Frequency		Hz	50	50	50
Heating stove weight		kg	280	360	410
Maximum operating pressure		bar	2.5	2.5	2.5
Maximum operating temperature		°C	85	85	85
Flue pipe diameter		mm	100	120	120
Heating stove dimensions	Width	mm	827	986	986
	Height	mm	1371	1539	1524
	Depth	mm	988	1052	1202
Heating stove connections	Flow pipe	Inch	1	5/4	5/4
	Return pipe	Inch	1	5/4	5/4
	Filling and draining	Inch	1/2	1/2	1/2
Fuel dimensions:					
- pellets		mm	30x6	30x6	30x6
Pellet hopper capacity		L	170	250	340

2. Display: Functions and Use



P1	Exit from menu (submenu)	P4	Adjusting combustion power +
P2	Ignition, shutdown, error (press and hold 3 sec). Activating chrono function	P5	Activating chrono time setting Accessing info menu
P3	Access to User Menu 1 and User Menu 2 (press and hold) Storing data	P6	Adjusting water temperature -
P3 + P5 (press and hold)	Direct access to secondary information		

D ☺ W ☺ WE ☺	Daily chrono activated Weekly chrono activated Weekend chrono activated	🚰	Domestic hot water/buffer request not satisfied
☀	Summer operation mode	❄	Winter operation mode
C	Combined mode (not active)	🔥	Wood-burning mode
🏠	Klimatik function (not active)	🔑	Room thermostat

3. Alarms

DESCRIPTION	STATUS	CODE
Safety thermostat HV1	<i>Blocked</i>	Er 01
boiler door open / Safety pressure switch	<i>Blocked</i>	Er 02
Shutdown due to low exhaust gas temperature	<i>Blocked</i>	Er 03
Shutdown due to high temperature of water in the boiler	<i>Blocked</i>	Er 04
Shutdown due to high exhaust gas temperature	<i>Blocked</i>	Er 05
Pellet thermostat open / High temperature in the pellet hopper	<i>Blocked</i>	Er 06
No encoder signal	<i>Blocked</i>	Er 07
Fan speed regulation failure	<i>Blocked</i>	Er 08
Low water pressure	<i>Blocked</i>	Er 09
High water pressure	<i>Blocked</i>	Er 10
Time and date not set	<i>Blocked</i>	Er 11
Ignition failure	<i>Blocked</i>	Er 12
Power supply failure	<i>Blocked</i>	Er 15
RS 485 communication error	<i>Blocked</i>	Er 16
Open probe for domestic hot water / buffer / boiler	<i>Blocked</i>	Er 23

4. Visualization

Description	Message
Anomaly detected during probe control in "Check Up" phase	Probe
Periodic cleaning in progress	Cleaning on
System in night mode	Night mode
Display firmware not compatible with main board	Keyboard not compatible

5. User Menu

<p>Operating Mode</p>	<p>This menu allows you to change the system's operating mode — switching from wood to pellet and vice versa, or selecting a combined mode. The menu is displayed only if P11 = 2, 3, 4.</p> <p>Switching from one operating mode to another is possible only in the following cases:</p> <ul style="list-style-type: none"> • when the system is OFF, any of the available modes can be selected • when the system is ON and P11=2, the operating mode cannot be changed • when the system is ON and P11=3, it is possible to switch from wood mode to combined mode • when the system is ON and P11=4, it is possible to switch from wood/pellet mode to combined mode
<p>Power</p>	<p>PELLET</p> <p>This menu allows you to adjust the combustion power when the system operates in pellet mode. It can be set to automatic or manual mode: in automatic mode, the system selects the combustion power; in manual mode, the user selects the desired power level. The left side of the display shows the combustion mode (A=automatic, M=manual) and the system operating power. Regarding burner system, automatic power cannot be adjusted. The menu appears if P11 ≠ 1.</p> <p>WOOD</p> <p>This menu allows you to adjust the combustion power when the system operates in wood mode. It can be set to automatic or manual mode: in automatic mode, the system selects the combustion power; in manual mode, the user selects the power level. The left side of the display shows the combustion mode (A=automatic combustion, M=manual combustion), as well as system operating power. Regarding burner system, automatic power cannot be adjusted. It appears if A36=1 and P11 ≠ 0.</p> <p>HEATING</p> <p>By entering this menu, it is possible to adjust the heating power. It can be set to automatic or manual mode: in automatic mode, the system selects the combustion power; in manual mode, the user selects the power level. If no output is configured as a heating fan or if parameter A04 = 1, this menu is not displayed.</p>

Thermostats	<p>This menu allows the modification of main thermostat values. The menu is not displayed for burner systems.</p> <p>BOILER Menu for adjusting the boiler thermostat value. The minimum and maximum values can be programmed by adjusting thermostats Th26 and Th27. When the climate function is active, the thermostat value cannot be changed, as it is calculated automatically by the system. Displayed only if the boiler probe is configured.</p> <p>DHW Menu for adjusting the domestic hot water thermostat value; displayed if the hydraulic system is configured as a hot water tank. The minimum and maximum values can be programmed by adjusting</p>
	<p>thermostats Th51 and Th52.</p> <p>BUFFER Menu for changing the buffer tank thermostat value; displayed if the hydraulic system which includes a buffer tank is selected. The minimum and maximum values can be programmed by adjusting thermostats Th51 and Th52. When the climate function is ON, its value cannot be changed, because it is automatically calculated by the system</p>
Chrono	<p>This menu allows programming system ignition and shutdown times. It consists of 2 sub-menus.</p>

<p>Function</p>	<p>OPERATING MODE Allows you to select the desired mode or disable all programming.</p> <ul style="list-style-type: none"> • enter edit mode using button P3 • select the desired mode (daily, weekly, or weekend) • save the new settings using P3 button. <p>PROGRAM The system offers three types of programming: daily, weekly, weekend After selecting the desired type of program:</p> <ul style="list-style-type: none"> • Select the time slot you wish to program using P6 or P4 buttons • Enter edit mode (the selected time slot is blinking) using button P3 • change the times using P6 or P4 buttons • save the programs using P3 button. • enable (“V” displayed) or disable (no “V” displayed) the selected time slot by pressing P5 button <p>DAILY Choose day in a week you wish to program and set ignition and shutdown times accordingly.</p> <p style="text-align: center;"><i>Programming after midnight</i></p> <p>Set the desired switch-on time on the previous day: for example 8:30 PM Set switch-off time on the previous day to 11:59 PM Set switch-on time on the following day to 12:00 AM</p>	<div style="border: 1px solid black; padding: 5px; margin-bottom: 10px;"> Deactivated Daily Weekly Weekend </div> <div style="border: 1px solid black; padding: 5px; margin-bottom: 10px;"> Monday ON OFF 09:30 11:15 V 00:00 00:00 00:00 00:00 </div> <div style="border: 1px solid black; padding: 5px;"> Monday Tuesday Wednesday Thursday </div>
	<p>Set the switch-off time on the following day to the desired value: for example 6:30 AM The system will switch on at 08:30 PM on Tuesday and switch off at 06:30 AM on Wednesday.</p> <p>WEEKLY The program is the same for all days.</p> <p>WEEKEND Select between Monday-Friday and Saturday-Sunday and set ignition and shutdown times accordingly.</p>	<div style="border: 1px solid black; padding: 5px;"> Mon-Fri Sat-Sun </div>

5.1 User Menu 2

Settings	Date and time	
	This function allows you to set the current day, month, year, and time.	
	Language	
	Menu for changing the language of the control panel/display.	
	Recipe	
	Menu for selecting the combustion recipe; if P04=1, this menu is not displayed.	
	Summer – Winter	
		This menu allows adjustment of the hydraulic system's operation according to the season. Displayed only if the hydraulic system is selected.
Service	Counters	
	Number of ignitions	Total number of ignitions
	Ignition failure	Total number of failed ignitions
	Operating hours	Hours of operation in run, modulation, and safety modes.
	Error log	
		This menu displays the last 10 errors; each line shows the error code and the date/time when it occurred. Enter the counter reset menu to clear this list.

Secondary information	
Information on configurable inputs and outputs is available only if these have been previously set.	
<i>Display</i>	<i>Description</i>
592	NG01 Wood-Pellet Evo Code.
xyzt	Manufacturer code
Fan	Exhaust gas fan speed (V1 output)

Output (C)	Output status (ON/OFF) or reducer speed (rpm) if P81=1, 2 and the output is configured as a reducer.
Output (V2)	Output status (ON/OFF)
Output (A1)	Output status (ON/OFF)
Output (A2)	Output status (ON/OFF)
Output PW1	Output status (ON/OFF)
Output PW2	Output status (ON/OFF)
Airflow	Airflow: displayed if the input is configured as the primary air regulator.
T of exhaust gases	Temperature of exhaust gases.
T of water	Temperature of boiler. Visible only if the system is configured as a hydraulic system.
T of buffer	Buffer tank temperature: displayed if the input is configured as the DHW/buffer tank probe and the hydraulic system with buffer tank is selected.
T of domestic hot water	Temperature of DHW: displayed if the input is configured as a DHW tank probe and if the hydraulic system with DHW tank is selected.
Input (IN2)	Input status (digital only): open->0, closed->1.
Input (IN3)	Input status (digital only): open->0, closed->1.
Input (IN4)	Input status (digital only): open->0, closed->1.

	Input (IN6)	Input status (digital only): open->0, closed->1.
	Input (IN7)	Input status (digital only): open->0, closed->1.
	Input (HV1)	Input status: open->0, closed->1.
	Input (HV2)	Input status: open->0, closed->1.

	<p>Reducer calibration</p> <p>This menu allows adjustment of the default reducer speed or switch-on time. Values can be set in the range from –7 to +7. Default value is 0. The menu is displayed only if A64=1.</p>
	<p>Fan calibration</p> <p>This menu allows adjustment of the default combustion fan speed. Values can be set in the range from –7 to +7. Default value is 0. The menu is displayed only if A64=1.</p>
	<p>Automatic combustion power</p> <p>This menu allows adjustment of the combustion power only in automatic mode. If setting is performed, the manual power adjustment menus will no longer appear.</p> <p>The menu is not displayed for burner systems.</p>
	<p>Pellet loading</p> <p>This function manually activates pellet loading and automatically stops after 300 seconds. The system must be OFF for this operation to be performed.</p>
<p>Display</p>	<p>Contrast</p> <p>Allows adjustment of the screen contrast.</p>
	<p>Acoustic alarm</p> <p>Menu for enabling/disabling the sound alarm.</p> <p>Firmware codes</p> <p>This menu displays the communication address of the control board, board type, and firmware versions. Possible board types displayed are:</p> <p>MSTR Master INP inputs KEYB keyboard OUT outputs</p> <p>CMPS composite SENS sensors COM communication</p>
	<p>Control board address</p> <p>Password-protected menu (default password is 1810) allowing configuration of the RS485 node address. Within the 485 bus, multiple nodes cannot share the same address.</p>

System menu

Minimum brightness

Allows adjustment of the screen brightness when the controls are not used.

Menu for accessing data reserved for technical personnel only. Access is password-protected.

6. Hydraulic System

6.1. Hydraulic System Selection

By adjusting parameter P26, you can select the most suitable hydraulic system configuration.

System pump lock via room thermostat:

- available above the thermostat activation value for the pumps Th19 or Th59 (for system 4).
- in systems 0 and 2, if there is a demand for water, pump P1 is not blocked and will reactivate if it was previously blocked.

Electrical wiring:

S1 = boiler probe

P1 = pump P1

S2 = boiler/buffer probe

P2 = pump P2/solenoid valve

FL = flow regulator

Configuration 0

When parameter **P26 = 0**, the configuration shown in Figures 1 and 2 is selected.

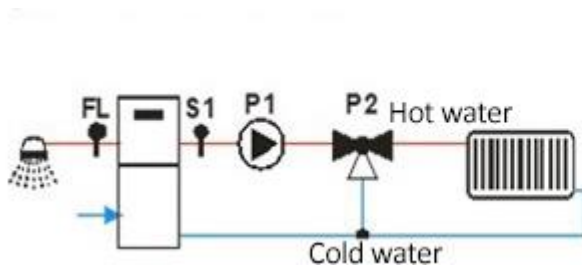

Fig. 1

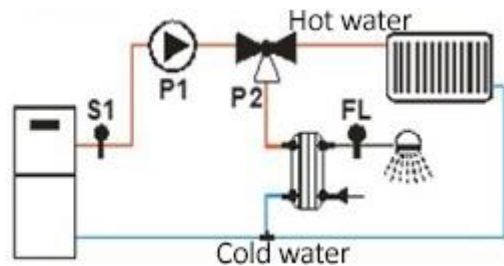

Fig. 2

Heating

The pump switches on when the temperature exceeds the thermostat Th20 value; to prevent water freezing, it switches on if the water temperature drops below the thermostat Th18 value. If the water temperature exceeds the thermostat Th21 value, for safety reasons, the pump remains continuously on.

Water recirculation

When there is a demand for domestic water and the boiler water temperature exceeds the thermostat Th19 value, or when the boiler water temperature exceeds the thermostat Th20, the valve is activated.

If the water temperature exceeds the thermostat Th21 value, the valve directs the water toward the system.

Example: Th18 = 5 °C, Th19 = 40 °C, Th20 = 30 °C, Th21 = 70 °C

Configuration 1

When parameter **P26 = 1**, the configuration shown in Figures 3 and 4 is selected

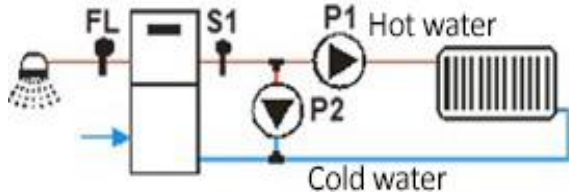

Fig. 3

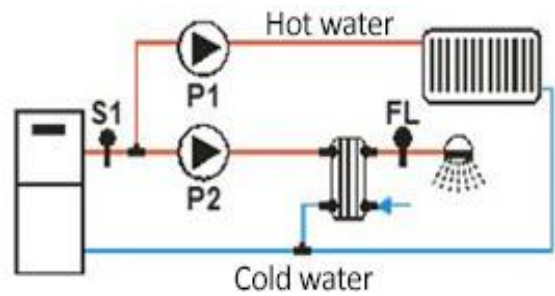

Fig. 4

Temperature of water	Flow regulator	Model	Operating mode	Valve P2	Pump P1
$T < 5^{\circ}\text{C}$	-	-	-	system (OFF)	ON
$5^{\circ}\text{C} \leq T < 30^{\circ}\text{C}$	-	-	-	system (OFF)	OFF
$30^{\circ}\text{C} \leq T < 40^{\circ}\text{C}$	-	-	-	recirculation (ON)	ON
$40^{\circ}\text{C} \leq T < 70^{\circ}\text{C}$	Open	Winter	Pellet	system (OFF)	ON
		Summer	Pellet	recirculation (ON)	OFF
	-	Wood	system (OFF)	ON	
	Closed	-	-	recirculation (ON)	ON
$T \geq 70^{\circ}\text{C}$	-	-	-	system (OFF)	ON

Heating

Pump P1 switches on when the temperature exceeds the pump activation thermostat Th19 and is disabled when there is a demand for domestic water.

To prevent freezing, pump P1 switches on if the water temperature drops below the thermostat Th18 value. For safety reasons, if the water temperature exceeds the thermostat Th21 value, pump P1 remains continuously on.

Water recirculation

When there is a demand for domestic water and the boiler water temperature exceeds the thermostat Th19 value, or the boiler water temperature exceeds the thermostat Th20 value, the pump P2 is activated.

If the water temperature exceeds the thermostat Th21 value, the pump P2 is deactivated.

Example: Th18 = 5 °C, Th19 = 40 °C, Th20 = 30 °C, Th21 = 70 °C

Temperature of water	Flow regulator	Model	Operating mode	Pump P2	Pump P1
$T < 5^{\circ}\text{C}$	-	-	-	OFF	ON
$5^{\circ}\text{C} \leq T < 30^{\circ}\text{C}$	-	-	-	OFF	OFF
$30^{\circ}\text{C} \leq T < 40^{\circ}\text{C}$	-	-	-	ON	OFF
$40^{\circ}\text{C} \leq T < 70^{\circ}\text{C}$	Open	Winter	Pellet	OFF	ON
		Summer	Pellet	OFF	OFF
		-	Wood	OFF	ON
	Closed	-	-	ON	OFF
$T \geq 70^{\circ}\text{C}$	-	-	-	OFF	ON

Configuration 2

When parameter **P26=2**, the configuration shown in Figure 5 is selected:

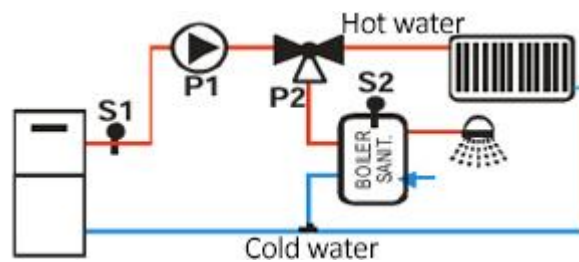

Fig. 5

Heating

Pump P1 switches on if the water temperature in the boiler exceeds the thermostat Th20 value and the difference between the temperatures detected by probes S1 and S2 is greater than the thermostat Th57 value.

The pump also switches on if the water temperature in the boiler exceeds the thermostat Th19 value. To prevent water freezing, the pump switches on if the water temperature drops below the thermostat Th18 value. For safety reasons, if the water temperature exceeds the thermostat Th21 value, the pump remains continuously on.

Domestic Hot Water

The valve is directed towards DHW tank if the water temperature does not exceed

Probe S1 T.	Probe S2 T.	Model	Operating mode	Difference	Valve P2	Pump P1
$T < 5^{\circ}\text{C}$	-	-	-	-	system (OFF)	ON
$5^{\circ}\text{C} \leq T < 50^{\circ}\text{C}$	$T > 55^{\circ}\text{C}$	Winter	-	-	system (OFF)	OFF
	$T < 55^{\circ}\text{C}$	Winter	-	-	recirculation (ON)	OFF
		Summer	-	-	recirculation (ON)	OFF
$50^{\circ}\text{C} \leq T < 65^{\circ}\text{C}$	$T < 55^{\circ}\text{C}$	-	-	$< 5^{\circ}\text{C}$	recirculation (ON)	OFF
		-	-	$\geq 5^{\circ}\text{C}$	recirculation (ON)	ON
	$T > 55^{\circ}\text{C}$	Winter	-	-	system (OFF)	OFF
		Summer	-	$< 5^{\circ}\text{C}$	recirculation (ON)	OFF
		Summer	-	$\geq 5^{\circ}\text{C}$	recirculation (ON)	ON
	$65^{\circ}\text{C} \leq T < 70^{\circ}\text{C}$	$T < 55^{\circ}\text{C}$	-	-	$< 5^{\circ}\text{C}$	recirculation (ON)
-			-	$\geq 5^{\circ}\text{C}$	recirculation (ON)	ON
$T > 55^{\circ}\text{C}$		Winter	Wood	-	system (OFF)	ON
		Summer	Wood	-	recirculation (ON)	ON
		Winter	Pellet	-	system (OFF)	ON
		Summer	Pellet	$< 5^{\circ}\text{C}$	recirculation (ON)	OFF
		Summer	Pellet	$\geq 5^{\circ}\text{C}$	recirculation (ON)	ON
$T \geq 70^{\circ}\text{C}$	-	-	-	-	system (OFF)	ON

the DHW tank/buffer tank thermostat value and if the water temperature in the boiler exceeds the thermostat Th20 value.

For safety reasons, if the water temperature in the boiler exceeds the thermostat Th21 value, the valve directs the flow toward the system.

Example: Th18 = 5 °C, Th19 = 65 °C, Th20 = 50 °C, Th21 = 70 °C, Th57 = 5 °C, DHW/Buffer Tank Thermostat = 55 °C

Configuration 3

When parameter P26=3, the configuration shown in Figure 6 is selected.

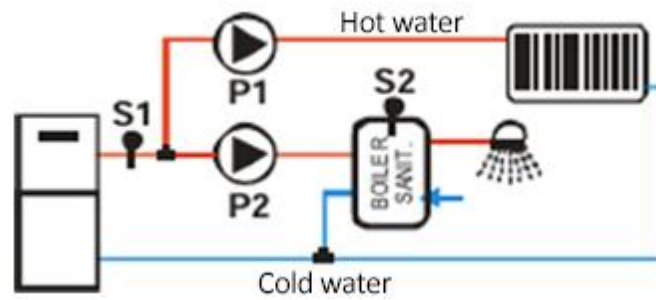

Fig. 6

Heating

Pump P1 switches on when the temperature exceeds the thermostat Th19 value, provided that the difference between the temperatures detected by probes S1 and S2 is lower than the thermostat Th57 value. To prevent water freezing, the pump switches on if the water temperature drops below the thermostat Th18 value or rises above the thermostat Th21 value.

Domestic Hot Water

Pump P2 is responsible for heating the water in the DHW tank. It operates only if the water temperature in the boiler exceeds the thermostat Th20 value and if the difference between the temperatures detected by probes S1 and S2 is greater than the thermostat Th57 value.

For safety reasons, if the water temperature in the boiler exceeds the thermostat Th21 value, pump P2 switches off.

Example: Th18 = 5 °C, Th19 = 65 °C, Th20 = 50 °C, Th21 = 70 °C, Th57 = 5 °C, DHW/buffer tank thermostat = 55 °C

Configuration 4

When parameter **P26=4**, the configuration shown in Figure 7 is selected:

Probe S1 T.	Probe S2 T.	Model	Operating mode	Difference	Pump P2	Pump P1
$T < 5^{\circ}\text{C}$	-	-	-	-	OFF	ON
$5^{\circ}\text{C} \leq T < 50^{\circ}\text{C}$	-	-	-	-	OFF	OFF
$50^{\circ}\text{C} \leq T < 65^{\circ}\text{C}$	$T < 55^{\circ}\text{C}$	-	-	$< 5^{\circ}\text{C}$	OFF	OFF
		-	-	$\geq 5^{\circ}\text{C}$		OFF
	$T > 55^{\circ}\text{C}$	-	-	$< 5^{\circ}\text{C}$	OFF	OFF
		Winter	-	$\geq 5^{\circ}\text{C}$	OFF	OFF
		Summer	-	$\geq 5^{\circ}\text{C}$	ON	OFF
$65^{\circ}\text{C} \leq T < 70^{\circ}\text{C}$	$T < 55^{\circ}\text{C}$	-	-	$< 5^{\circ}\text{C}$	OFF	OFF
		-	-	$\geq 5^{\circ}\text{C}$	ON	OFF
	$T > 55^{\circ}\text{C}$	-	Wood	-	OFF	ON
		Winter	Pellet	-	OFF	ON
		Summer	Pellet	$< 5^{\circ}\text{C}$	OFF	OFF
		Summer	Pellet	$\geq 5^{\circ}\text{C}$	ON	OFF
$T \geq 70^{\circ}\text{C}$	-	-	-	-	OFF	ON

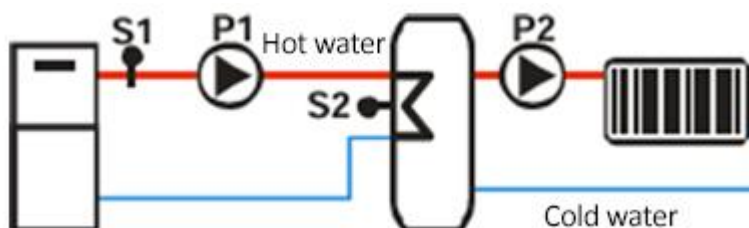

Fig. 7

Buffer Tank Loading

If the temperature in the boiler is higher than the pump activation thermostat Th19 value, the system heats the water in the buffer tank when there is a difference between the two probes (temperature in the boiler less temperature in the buffer tank greater than the differential thermostat Th57 value). For safety reasons, if the water temperature in the boiler exceeds the thermostat Th21 value, pump P1 switches on. Pump P2 switches on when the temperature exceeds the thermostat Th59 value.

Example: Th18 = 5 °C, Th19 = 40 °C, Th21 = 70 °C, Th57 = 5 °C, Th59 = 50 °C

Probe S1 T.	Difference		Pump P2
T < 5°C	-		ON
T < 40°C	-		OFF
T ≥ 40°C	< 5°C		OFF
	≥ 5°C		ON
T ≥ 70°C	-		ON
Probe S2 T.	Model	Operating mode	Pump P1
T < 50°C	-	-	OFF
T ≥ 50°C	Winter	-	ON
	Summer	Wood	ON
	Summer	Pellet	OFF

Configuration 5

When parameter **P26=5**, the configuration shown in Figure 8 is selected:

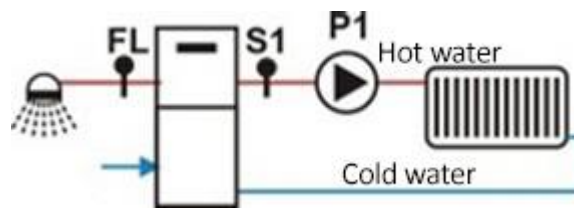

Fig. 8

Heating

The pump switches on when the temperature exceeds the pump activation thermostat Th19 value. To prevent water freezing, the pump also switches on if the water temperature drops below the thermostat Th18 value. For safety reasons, if the water temperature exceeds the thermostat Th21 value, the pump remains continuously on.

Domestic Hot Water

When there is a demand for domestic water, the system blocks the pump.

Example: Th18 = 5 °C, Th19 = 40 °C, Th21 = 70 °C

Water temperature	Model	Flow regulator	Pump
T < 5°C	-	-	ON
5°C < T < 40°C	-	-	OFF

40°C < T < 70°C	Summer	-	OFF
	Winter	Closed	OFF
	Winter	Open	ON
T > 70°C	-	-	ON

Configuration 6

When parameter **P26=6**, the configuration shown in Figure 9 is selected

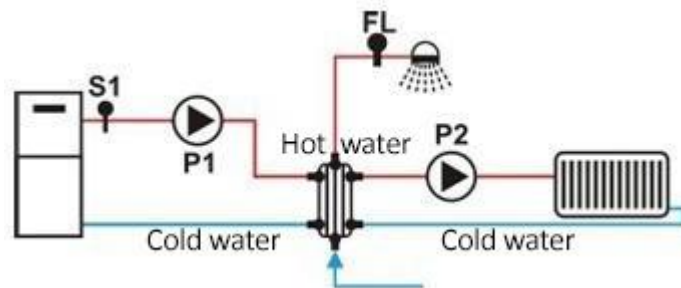

Fig. 9

Heating

Pump P2 switches on when the temperature exceeds the thermostat Th19 value, provided there is no demand for domestic water. To prevent water freezing, pump P2 switches on if the water temperature drops below the thermostat Th18 value or rises above the thermostat Th21 value.

Domestic Hot Water

Pump P1 switches on when the temperature exceeds the thermostat Th20 value. To prevent water freezing, the pump switches on if the water temperature drops below the thermostat Th18 value.

Example: Th18 = 5 °C, Th19 = 40 °C, Th20 = 30 °C, Th21 = 70 °C

Probe S1 T.	Flow regulator	Model	Operating mode	Pump P2	Pump P1
T < 5°C	-	-	-	ON	ON
5°C ≤ T < 30°C	-	-	-	OFF	OFF
30°C ≤ T < 40°C	-	-	-	ON	OFF

40°C ≤ T < 70°C	Closed	-	-	ON	OFF
	Open	Winter	-	ON	ON
		Summer	Wood	ON	OFF
		Summer	Pellet	ON	OFF
T ≥ 70°C	-	-	-	ON	ON

6.2. Domestic Hot Water Function

In hydraulic systems with a flow regulator or a DHW buffer tank, when there is a demand for domestic water, the DHW function switches on, and the boiler thermostat value becomes equal to the value of thermostat **Th21-lh21**. When the demand ceases, the function ends after the time period **T68** has elapsed.

7. Operating States (Functions)

7.1 Blocked

To exit the blocked state, press the unblock button (P2) and hold it for 3 seconds; if the blocking conditions no longer exist, the system will switch off.

Parameters	Status control	Fan	Reducer	Heater/igniter
	t. of exhaust flue gases > Th01	V11	OFF	OFF
	t. of exhaust flue gases < Th01	OFF	OFF	OFF

7.2 Off Mode

Parameters	Status control	Fan	Reducer	Heater/igniter
	t. of exhaust flue gases > Th01	OFF	OFF	OFF
	→ switches to shutdown mode if the system was previously in the pellet mode			
	Temperature of water > Th25			
	→ switches to Blocked			

7.3 Check up

Parameters	Status control		Fan	Reducer	Heater/ igniter
T01	t. of exhaust gas > Th09 and system was previously in pellet mode	→ switches to run mode	Maximum speed	OFF	OFF
	t. of exhaust gases > T01 and T11 and system was previously in the wood or combined mode	→ switches to recovery ignition			
	Check up upon expiration of T01	→ switches to ignition			

7.4 Ignition

* Preheating

Parameters	Status control		Fan	Reducer	Heater/ igniter
T02	t. of exhaust gases > Th09	→ switches to run mode	V24	OFF	ON

* Preloading

Parameters	Status control		Fan	Reducer	Heater/ igniter
T03	t. of exhaust gases > Th09	→ switches to run mode	V01	ON	ON
T29				OFF	

* Fixed ignition phase

During the entire phase, the minimum temperature of exhaust gases is maintained.					
Parameters	Status control		Fan	Reducer	Heater/ igniter
T04	t. of exhaust gases > Th09	→ switches to run mode	V01	C01	ON

* Variable ignition phase

During the entire phase, the minimum temperature of exhaust gases is maintained.					
Parameters	Status control		Fan	Reducer	Heater/ igniter
	t. of exhaust gases > Th09	→ switches to run mode			

T05	t. of exhaust flue gases > Th06 and t. of exhaust flue gases > than minimum stored value + D41	→ switches to stabilization	I ignition: V01	I ignition: C01	ON
Check up upon expiration of T05	t of exhaust flue gases < Th06 or t	→ switches to re-ignition	II ignition: V10	II ignition: C10	
	of exhaust flue gases < than minimum stored value + D41	attempt from the variable phase → switches to shutdown with error Er12 if the allowed number of attempts has been reached			

* *Stabilization*

<i>Parameters</i>	<i>Status control</i>		<i>Fan</i>	<i>Reducer</i>	<i>Heater/igniter</i>
T06	t. of exhaust gases > Th09	→ switches to run mode	V02	C02	ON if the temperature of exhaust gases < Th02 , otherwise OFF
	t. of exhaust flue gases < Th06	→ switches to re-ignition from variable phase			
		→ switches to shutdown with error Er12 if the allowed number of attempts has been reached			
Check up upon expiration of T06	t. of exhaust gases > Th06+D01	→ switches to run mode			
		→ switches to re-ignition from variable phase			
	t. of exhaust flue gases < Th06+D01	→ switches to shutdown with error Er12 if the allowed number of attempts has been reached			

* *Recovery ignition*

*If the system switches to re-ignition from control for an exhaust gas temperature greater than **Th11**, the reference thermostat for re-ignition phases*

is no longer Th01 but Th11.

Parameters	Status control		Fan	Reducer	Heater/ igniter
T13	t. of exhaust flue gases > Th01	→ timer T13 is started	V09	OFF	OFF
Check up upon expiration of T13	t. of exhaust flue gases > Th01	→ waiting			

** Cleaning burner*

Parameters	Status control	Fan	Reducer	Heater/ igniter
	This phase, performed at the end of the waiting phase, is only present if set as Motor Cleaning and ends when the motor stops.	OFF	OFF	OFF

** Final cleaning*

Parameters	Status control		Fan	Reducer	Heater/ igniter
T16	t. of exhaust flue gases < Th01	→ Timer for final cleaning T16 is started	Maximum speed	OFF	OFF
Check up upon expiration of T16	t. of exhaust flue gases < Th01	→ switches to check-up			

7.5 Run mode

Parameters	Status control		Fan	Reducer	Heater/ igniter
T14	t. of exhaust flue gases < Th03 or t. of exhaust flue gases < Shutdown thermostat for used power	→ timer T14 before waiting for shutdown is started	User power	User power	OFF
Check up upon expiration of T14	→ switches to shutdown with error Er03	→ switches to modulation			
	t. of exhaust flue gases > Th07				
	t. of water > Thermostat of hot water storage tank				

A01=1, and not Air system	Room temperature > Room thermostat *			
A01=2 or 4 and not Air system	Room temperature > Room thermostat *	→ switches to standby		
P26=2, 3	DHW temperature > Thermostat/DHW buffer tank and summer mode			
P26=4	t. of buffer tank > Thermostat/DHW buffer tank			
P26=0 A45=1	In summer mode, if there is no need for hot water			
	T of water > Th25	→ switches to safety		

**In a hydraulic system, this condition applies if there is no need for hot water or if a hydraulic system with a buffer tank is selected.*

If the system has just finished ignition, the shutdown thermostats and the thermostat **Th03** are measured at the end of **T14+T00**.

7.6 Modulation

Parameters	Status control		Fan	Reducer	Heater/ igniter
T14	t. of exhaust flue gases < Th03 or t. of exhaust flue gases < Shutdown thermostat for used power	→ timer T14 Waiting before shutdown is started	V11	C11	OFF
Check up upon expiration of T14	→ switches to shutdown with error Er03				
A01=2 or 4	room temperature > Room thermostat *				
A13=1	If during time T43 and t of water > Thermostat of boiler +D23				
A13=2	If during time T43 and summer mode and t of water > Thermostat of boiler +D23	→ switches to standby status Standby			
P26=2, 3	DHW temperature > Thermostat DHW/Buffer and summer mode				
P26=4	t. of buffer tank > Thermostat DHW/Buffer tank				
P26=0 A45=1	In summer mode, if there is no need for hot water				
	t. of exhaust gases > Th08	→ switches to Safety			
	water temperature > Th25				

In a hydraulic system, this condition applies if there is no need for hot water or if a hydraulic system with a buffer tank is selected. If the system has just finished ignition, the **shutdown thermostat and the thermostat **Th03** are measured at the end of **T14+T00**.*

7.7 Standby

When the conditions that brought the system to standby are no longer met, timer **T11** is started. After its expiration, the system switches to the check up mode. If the exhaust gas temperature is > **Thermostat Th08** (only if

the system allows the use of thermocouples in pellet mode), water temperature > **Thermostat Th25** or air temperature > **Thermostat Th25**, the system switches to safety mode. Depending on the value of parameter **A27**, the burner can be maintained or switched off and cleaned.

7.8 Safety

<i>Parameters</i>	<i>Status control</i>		<i>Fan</i>	<i>Reducer</i>	<i>Heater/igniter</i>
T15	t of exhaust gases < Th08 and t of water < Th25 and t of air < Th25	→ switches to previous status	V12 if previously it was in standby status, V11 if it was in modulation	OFF	OFF
Check up upon expiration of T15	→ switches to shutdown with error Er05 or Er04				

7.9 Shutdown

<i>Parameters</i>	<i>Status control</i>		<i>Fan</i>	<i>Reducer</i>	<i>Heater/igniter</i>
T13	t. of exhaust flue gases > Th01	→ timer T13 is started	V09	OFF	OFF
Check up upon expiration of T13	t. of exhaust flue gases > Th01	→ waiting			

8. Final cleaning

<i>Parameters</i>	<i>Status control</i>		<i>Fan</i>	<i>Reducer</i>	<i>Heater/igniter</i>
T16	t. of exhaust flue gases < Th01	→ timer T16 is started	Maximum speed	OFF	OFF
Check up upon expiration of T16	→ switches to OFF without error, otherwise switches to Blocked		OFF		

8.1 Selecting combustion power

Automatic mode

When adjusting the operating power, the user can set the automatic [A] or manual [M] mode; if the automatic mode is selected, the power will be automatically adjusted based on the main temperature and set value of the main thermostat.

If:

* main temperature ≤ main thermostat **-D08** → system runs at maximum power

- * main thermostat **-D08** < main temperature < main thermostat → combustion power is selected proportionally (the greater the difference between the water temperature and the thermostat value, the greater the selected power)
- * main temperature ≥ main thermostat → system operates at power setting 1 or, if enabled, at modulation power

Example: System=Hydro, Mode=[A], Boiler thermostat =60°C, D08 =20 °C, P03 =5						
Water temperature °C	≤ 40	40 ÷ 45	46 ÷ 50	51 ÷ 55	56 ÷ 60	≥ 60
Combustion power	5	4	3	2	1	1 or Mod.

8.2 Reducer calibration

The user changes the switch-on time/pellet feeding speed in increments of $-7 \div +7$. **P15** is a percentage value of one increment and applies to the default values of operating power. The calculated values are set to be within the set range of **P27 ÷ P05**.

Example	P15 =10%	C03 =2.0	C04 =3.0	C05 =4.0	C06 =5.0	C07 =6.0	C11 =1.0
	Increment = -1	C03 =1.8	C04 =2.7	C05 =3.6	C06 =4.5	C07 =5.4	C11 =0.9

8.3 Fan calibration

The user changes the combustion fan speed in increments of $-7 \div +7$. **P16** is a percentage value of one increment applied to the default values of operating speeds. The calculated values are set to be within the set range **P14 ÷ P30**.

Example	P16 =5%	V03 =1000	V04 =1200	V05 =1400	V06 =1600	C07 =6.0	V11 =900
	Increment = +3	V03 =1150	V04 =1380	V05 =1610	V06 =1840	C07 =5.4	V11 =1035

9. Room thermostat

Depending on the value of parameter **A01**, the following happens:

* **A01**=0

open contact: the system switches to shutdown mode.

closed contact: the system switches to ignition.

* **A01=1**

closed contact: the system switches to run mode.

open contact: the system switches to modulation mode.

* **A01=2**

closed contact: the system switches to run mode.

open contact: the system switches to standby status.

* **A01=3**

closed contact: the system starts the pump.

open contact: if the water temperature exceeds the value of the thermostat which activates the system pump (**Th19** ili **Th59**), the system blocks the system pump until the value of the thermostat **Th21** or **Th78** is reached (if **P26=4**).

* **A01=4**

closed contact: the system restarts the pump and switches to run mode.

open contact: the system switches to standby status i blocks the system pump as in case 3.

10. Domestic hot water/buffer tank probe

Enable one of the configurable inputs as a hot water/buffer tank probe if the hydraulic system which includes that input is selected (P26=2, 3, 4).

11. Electromagnetic valve / Pump P2

The output controls a two-wire valve or a non-high-efficiency pump if a triac output is selected. In the case of using a 2-3-way module that switches the output from the triac to a relay, it is possible to connect a three-way electromagnetic valve or a high-efficiency pump. The operation of the connected device depends on the selected hydraulic system.

11.1 Pump P1

The output controls a non-high-efficiency pump if a triac output is selected. In the case of using a 2-3-way module that switches the output from the triac to

a relay, it is possible to connect a high-efficiency pump. The operation of the connected device depends on the selected hydraulic system.

12.0 Shutdown During Ignition Phase

When the system has already went through the pre-ignition phase and it is turned off by an external device (such as an internal or external chrono/timer), it completes ignition and stabilization and once fully operational, it switches to shutdown. The display shows the message "Ignition Blocked."

If error occurs, the system immediately enters shutdown with error mode.

Pressing the ignition button allows for immediate shutdown or recovery ignition.

13.0 Power Failure

*In the event of a power outage, the system retains the most important operational data. When power supply is restored, the system evaluates the stored data and, if data recovery is successful, based on parameter **A53**, the following occurs:*

** Recovery mode of status 0 (A53=0)*

*- If the power outage lasted less than **T88**, the system returns to its previous state.*

- If the system was on and the power outage occurred between T88 and T89, the system switches to recovery ignition.

*- If the power outage lasted longer than **T89**, the system enters a block mode with error **Er15**.*

14.0 User Manual

The combined pellet- and wood-fired boiler ABC COMBO is designed for burning pellets. The boiler is manufactured using state-of-the-art technology with high-quality certified materials, welded using modern robotic technology, and tested according to EN 303-5:2012 standard to meet all requirements for

connecting to central heating systems and European norms regarding efficiency and emissions.

- * During installation, all national, European, and local regulations must be observed.
- * Only original spare parts obtained from an authorized dealer, service shop, or directly from the factory may be used.
- * Combo boiler can be connected to open and closed type of central heating system. The installations must be executed in accordance with technical standards by a professional person who will be responsible for the correct operation of the boiler.
- * If the boiler is connected to an open central heating system, it is necessary to place the open expansion vessel at least 0.5 m above the height of the highest heating element. If the vessel is installed in a room that is not heated, it should be well insulated.
- * If the boiler is connected to a closed central heating system, it is mandatory to install a certified safety valve as well as a membrane expansion vessel. The safety valve and the expansion vessel must be installed according to the rules of the profession.
- * The boiler must not be used in flammable or explosive atmospheres. The product must not be used by children, persons with reduced physical or mental abilities, or persons lacking knowledge or experience, unless supervised or trained by a responsible person. Children must be supervised near the product.

14.1 Connecting the Boiler to the Chimney

A properly sized and constructed chimney is essential for safe boiler operation and heating efficiency. The chimney must be well insulated. Cleaning doors must be installed at the lower part of the chimney. The chimney must be resistant to flue gas condensation.

WARNING:



- * Horizontal flue pipe sections must have a minimum slope of 3%.
- * The horizontal flue pipes length should be minimal and in any case no longer than 3 m.
- * The number of direction changes in the flue pipes, including “T” elements, must not exceed 3.

14.2 Fuel

Pellets used should comply with the following standards: EN Plus, DIN Plus, ONorm-M-7135 or DIN 51731.

* Pellets

characteristics:

Moisture ---- 6 – 8%

Diameter ----6mm

Length----- 10 – 30 mm

Ash residue -----1%

14.3 Boiler Installation

Safety Distances from Walls and Other Objects

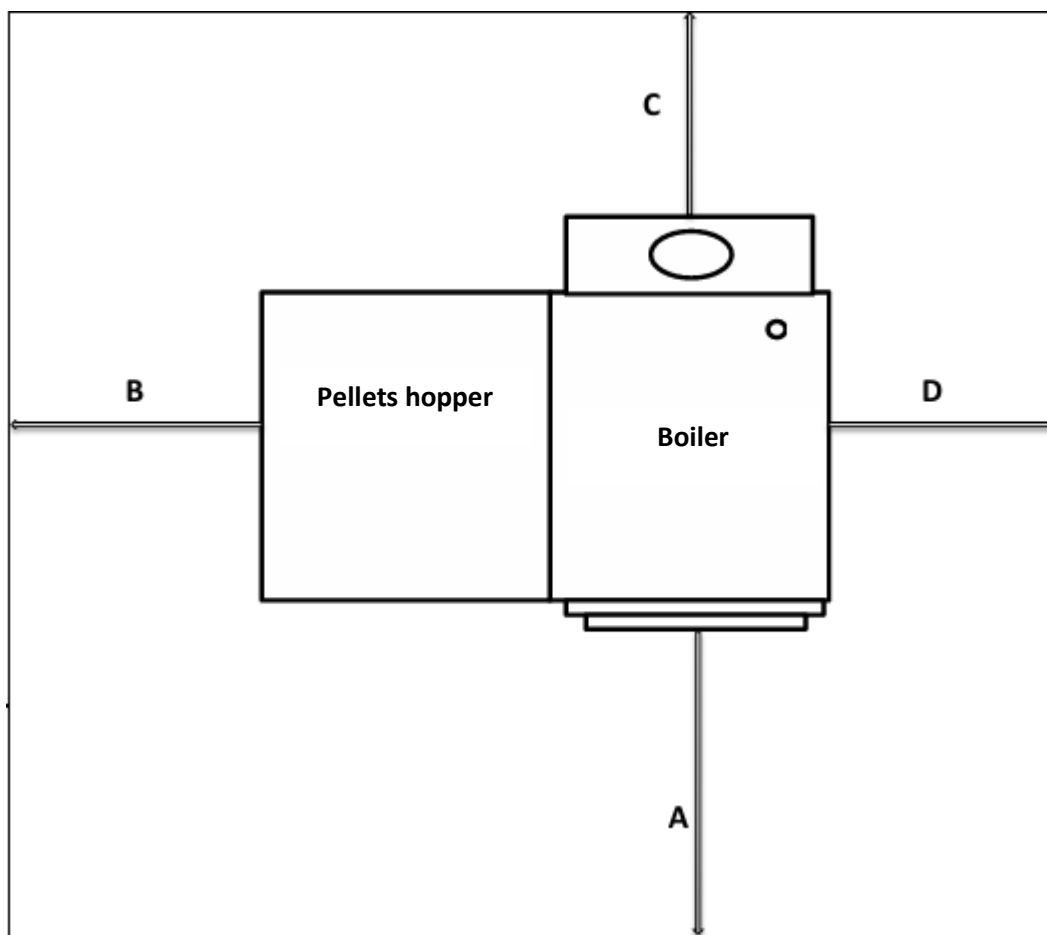

A = 800 mm

B = 150mm

C = 300mm

D = 500mm

The boiler room must have a fresh air inlet sized according to the boiler's power. Such inlet has to be protected with safety mesh or grid. All installation work must comply with applicable national and European standards. The boiler must not be used in flammable or explosive environments.

15 Connection Dimensions

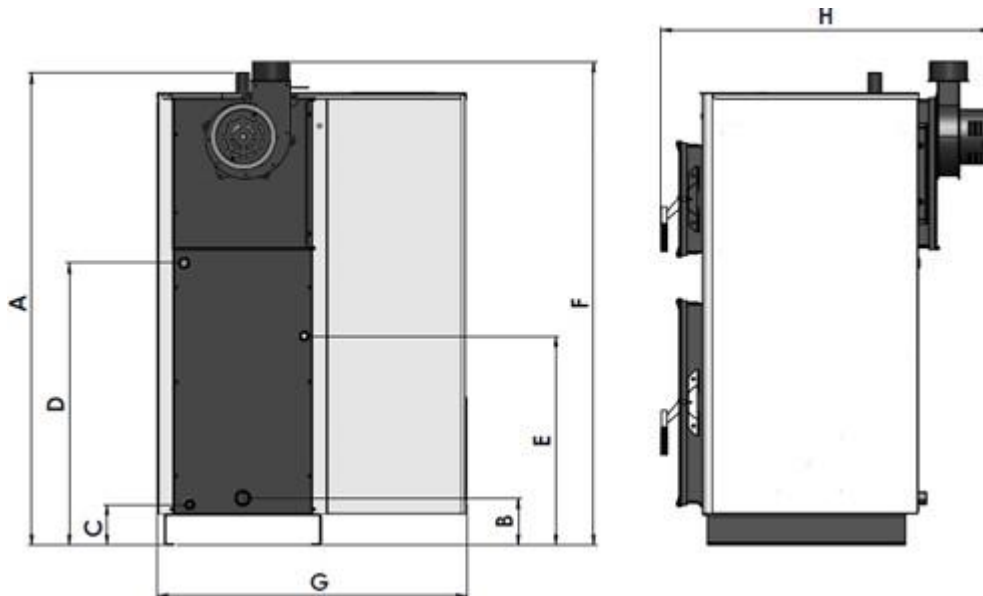

ABC COMBO 25kw

A – 1353mm – flow pipe

B – 150mm – return pipe

C – 130mm – filling and draining

D – 799mm – heat exchanger

E – 566mm – cold water supply

F – 1367mm – flue pipe / boiler height

G – 827mm – boiler width

H – 980mm – boiler depth

ABC COMBO 40-60kw

F – 1540mm – flue pipe / boiler height

A – 1504mm – flow pipe

B – 150mm – return pipe

C – 130mm – filling and draining

D – 899mm – heat exchanger

E – 665mm – cold water supply

G – 987mm – boiler width

H – 1052mm – boiler depth 40kw

H – 1202mm – boiler depth 60kw

15.1 Connecting the Pump and the Room Thermostat

Connections for connecting the circulation pump and the room thermostat are provided at the back of the boiler. It is necessary to unscrew the screws (Figure 3-1) and connect devices according to the attached connection diagram, which is located on the inside of the cover

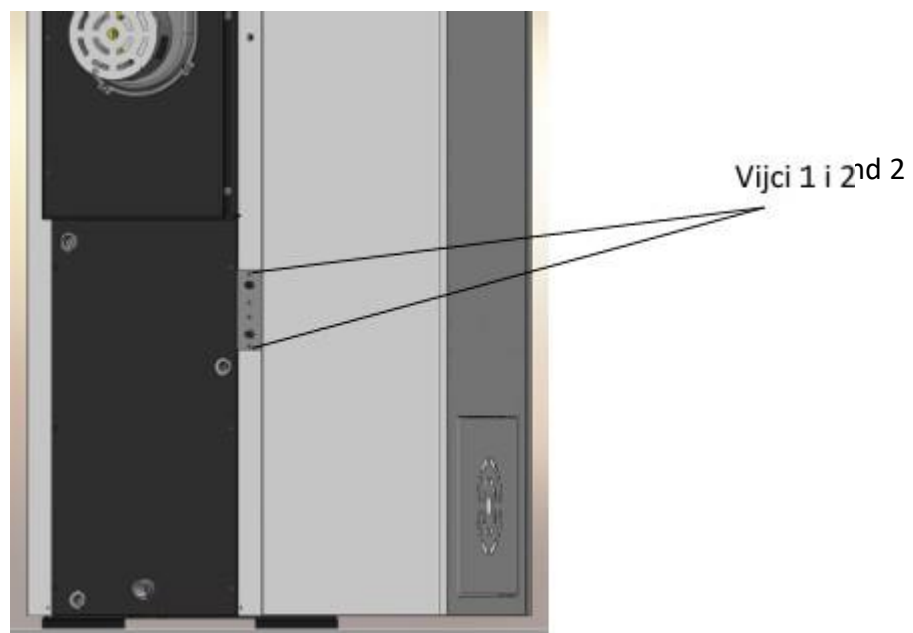

16 First Ignition of the Boiler

- Check that the burner is correctly positioned
- Check that all turbulator spirals are in place

- Connect the voltage cable to the 220V network
- Press the main switch to position 1
- Select boiler operation mode: pellets or solid fuel (the boiler is factory-set to pellets)
- Fill the hopper with pellets
- Activate the "Load" option (manual loading 5.5.3) and wait for the pellet to start entering the burner. Wait 10 - 15 seconds and stop charging via OFF button. The pellets in the burner must be emptied and the burner returned to its place, making sure that the opening on the left side of the burner rests on the heater tube.
- Close the bottom door of the boiler and start the boiler by long pressing the button P2
- Adjust the boiler power (section 5.1)
- Set the water temperature (chapter 5)

17 Boiler Cleaning and Maintenance

Every millimeter of soot and dust on exchangers and flue pipes means 5% higher pellet consumption. A clean boiler saves fuel and protects the environment.

USE OF PROTECTIVE GLOVES IS MANDATORY!



Daily cleaning:

- Depending on the intensity of the use, it is necessary to empty the ashtray at least once a day
- Scoop out the rest of the ashes in the firebox into the ashtray
- Take out the burner from the bed and clean it from the remains of pellets and ash deposits
- Clean the inside of the burner support from ash
- Pull the turbulator coils back and forth

Weekly cleaning:

- Open the upper door of the boiler and clean the ash deposits in the turbulators and on the sides of the boiler

- Remove the turbulators (spirals) and clean the pipes

Monthly cleaning:

- Detach the flue pipes and clean them

- Disconnect the cable from the fan

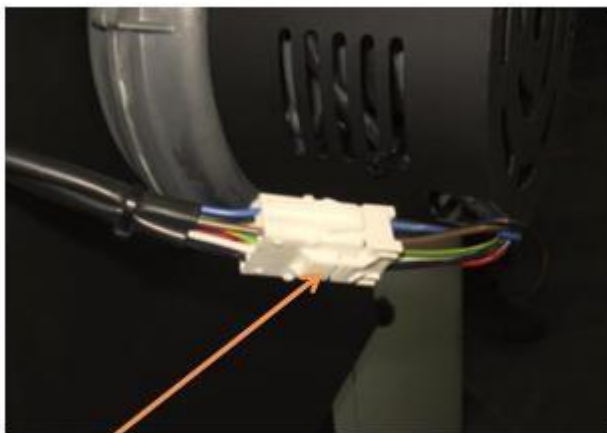

21

- Press the connector in the middle and pull back

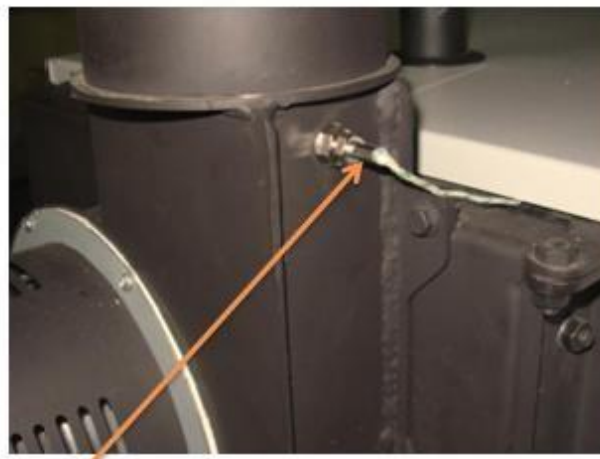

- Pull the exhaust gas temperature probe out of the housing
- Open the door of the cleaning opening (from the back of the boiler Fig. 7) and clean deposits of ash and debris

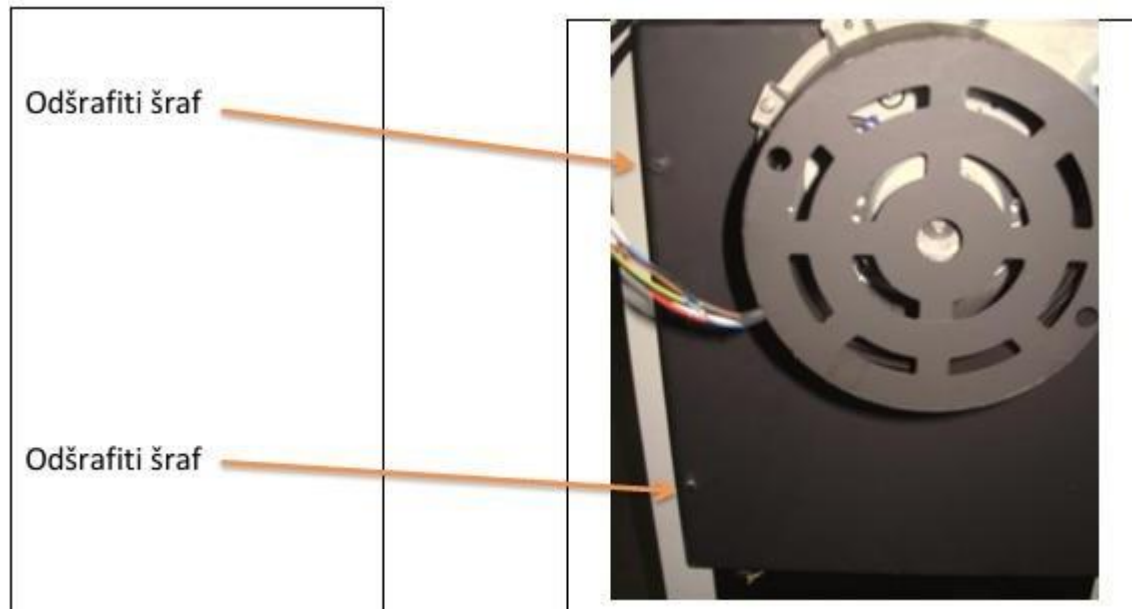

- After cleaning, repeat the assembly procedure in reverse order

At the end of the heating season:

- Remove the fan housing and vacuum the dust with a vacuum cleaner, taking care not to damage the fan propellers
- Clean the flue pipes and check the patency of the chimney
- Clean the pellet hopper from dust and small pellet residues
- Scrape deposits of ash and soot from all metal parts of the boiler in the combustion chamber as well as on the tube exchangers in the area of the upper door

Note:

At the end of the heating season, it is necessary to thoroughly clean the boiler of soot, and it is mandatory that the boiler is always filled with water, whether connected to a closed or open central heating system.

18 Dismantling the Pellet Hopper



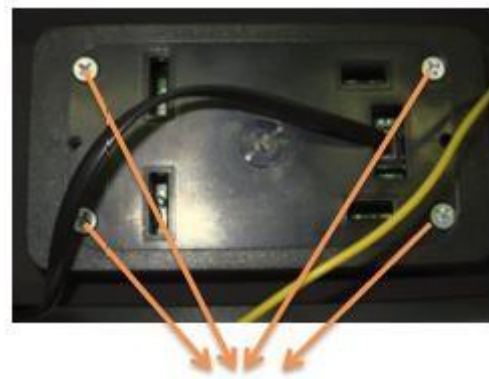

1. Detach the cables from the main switch

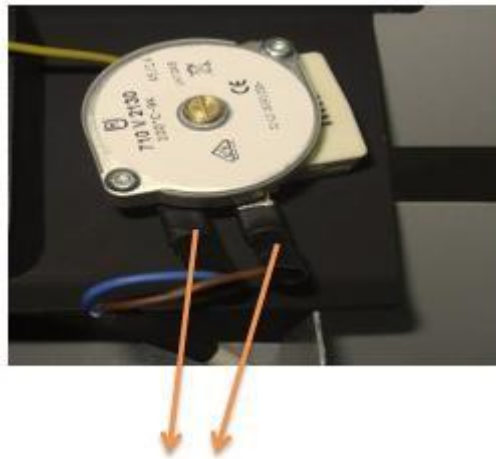

2. Unscrew the 4 screws on the display cover and then pull the cable out of the housing

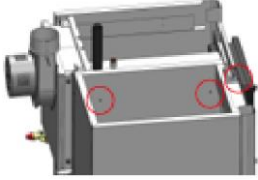
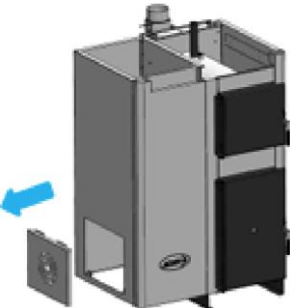

3. Disconnect the cables from the safety thermostat

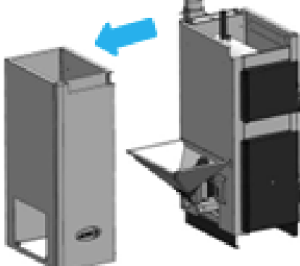
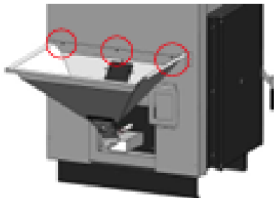
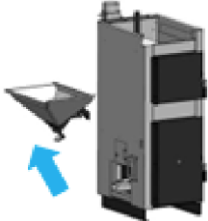
1.		<p>Remove the boiler cover.</p> <p>Before removing the cover, disconnect the electrical installation.</p> <ul style="list-style-type: none"> - main switch - display - safety thermostat
2.		<p>Unscrew the screws.</p> <p>Unscrew three screws marked on the drawing, from the inside of the storage.</p>
3.		<p>Remove the side cover of the housing.</p> <p>Reach with hand from the bottom side of the housing and press the lower corners of the side cover of the housing.</p>
4.		<p>Unscrew the screws.</p> <p>Unscrew two screws marked on the drawing, from the inside, under the hopper.</p>
5.		<p>Removing hopper.</p> <p>Lift the hopper 20mm and then remove it laterally in the direction of the arrow.</p>
6.		<p>Unscrew the screws.</p> <p>Unscrew three screws marked on the drawing, from the hopper funnel.</p>
7.		<p>Removing the hopper funnel together with the pellet feeder.</p> <p>Lift the hopper funnel together with the pellet feeder in the direction of the arrow (at an angle of 45°).</p>

Spare parts catalogue:

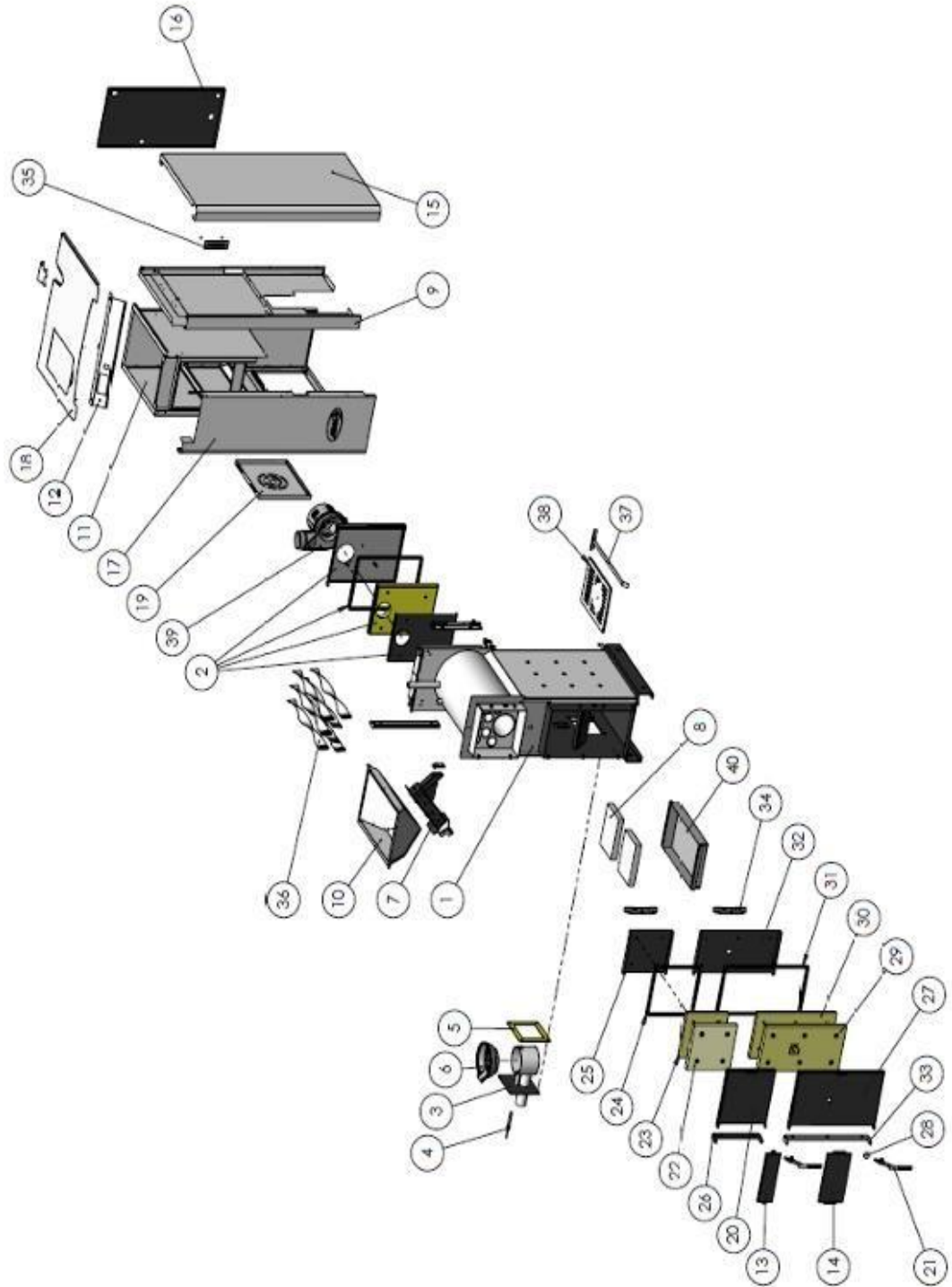

List of spare part positions:

No.	POSITION NAME	PCS	25KW	40KW	60KW
1.	Boiler stove with connections	1	S0670	S0637	S1102
2.	Flue gas chamber door	1	S0681	S0802	S0802
3.	Burner housing	1	S0510	S0613	S1086
4.	Igniter	1	P03077	P03077	P03077
5.	Burner housing gasket	1	P02210	P03040	P03265
6.	Burner	1	P02087	P02232	P02337
7.	Pellet feeder	1	S0615	S0615	S0615
8.	Fireclay plate	2	P00195	P02329	P02554
9.	Left side panel of the boiler	1	S0620	S0821	S0878
10.	Hopper funnel	1	S0618	S0646	S0885
11.	Hopper casing	1	S0804	S0805	S0879
12.	Display housing	1	P02044	P02184	P02184
13.	Mask	1	P02015	P02185	P02185
14.	Front panel	1	P02010	P02177	P02177
15.	Right side panel of the stove	1	S0679	S0819	S0877
16.	Rear panel of the stove	1	P02008	P02176	P02530
17.	Front panel of the hopper	1	S0807	S0823	S0823
18.	Cover	1	S0635	S0649	S0883
19.	Service access cover	1	P02345	P02345	P02345
20.	Upper door	1	P01840	S0642	S0642
21.	Door handle	2	S0145	S0145	S0145
22.	Upper door vermiculite board 2	1	P01843	P02138	P02138
23.	Upper door vermiculite board 1	1	P01844	P02139	P02139
24.	Upper door braid seal	1	P01842	P02140	P02140
25.	Upper door vermiculite protector	1	P01845	P02137	P02137
26.	Upper door hinge	1	P01846	P02134	P02134
27.	Lower door	1	P01850	P02128	P02128
28.	Viewing glass	1	P01877	P01877	P01877
29.	Lower door vermiculite board 2	1	P01853	P02131	P02131
30.	Lower door vermiculite board 1	1	P01854	P02132	P02132
31.	Lower door braid seal	1	P01852	P02133	P02133
32.	Lower door vermiculite protector	1	P01855	P02130	P02130
33.	Lower door hinge	1	P01856	P02127	P02127
34.	Door catch	1	S0606	S0606	S0606
35.	Connection for pump and room thermostat	1	S1056	S1056	S1056
36.	Turbulator spiral	7/11/13	P02254	P02157	P02553
37.	Cleaning tools	1	S0288	S0288	S0288
38.	Cast-iron fire grate	1	P01887	P02120	P02560
39.	Fan housing	1	P02276	S0803	S0803
49.	Ash drawer	1	S0349	S0644	S0888

* When ordering spare parts, state whether it is a left-hand or right-hand boiler

19. Electrical Wiring Scheme NG01

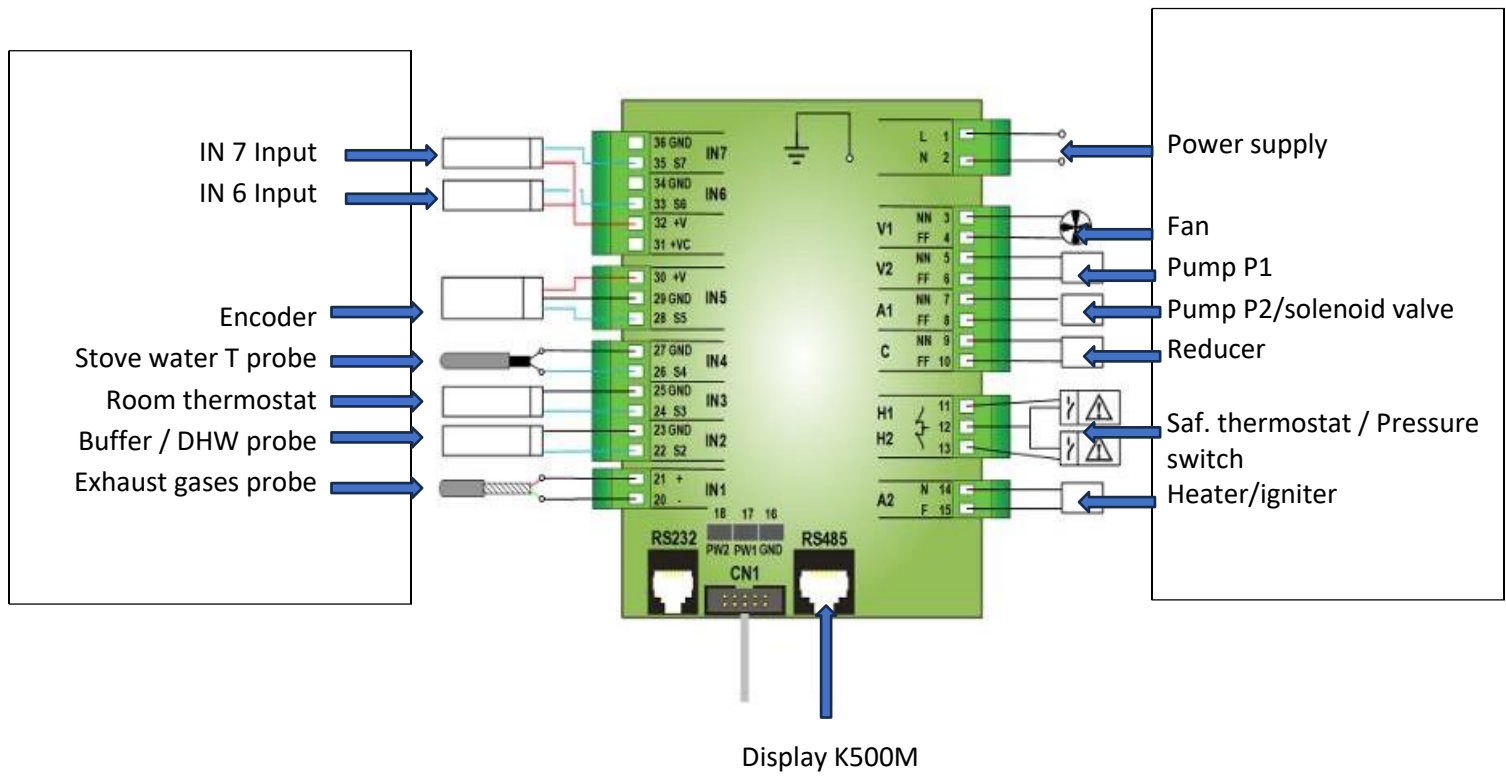

20. Appendix



Declaration of Conformity



Manufacturer:

„**ABC PROIZVOD**“ doo
2, Miloša Obrenovića St., 31000 Užice/ Serbia

Hereby declares that the pellet-fired room-heating appliance, with commercial name:
Combo, is in conformity with the requirements and provisions of
CE (Construction Products Directive) EU 305/2011, and conforms to the
following harmonized standard:

EN
EN 303-5:2012

The company “ABC PROIZVOD” doo, Užice, implemented a quality
management system:

SRPS ISO 9001/2015, in 2007, which is continuously maintained and
improved.

21. Table of Contents

1. *Technical Characteristics*
2. *Display: Functions and Use*
3. *Alarms*
4. *Visualization*
5. *User Menu*
 - 5.1 *User Menu 2*
6. *Hydraulic System*
 - 6.1 *Hydraulic System Selection*
 - 6.2 *Domestic Hot Water Function*
7. *Operating States (Functions)*
 - 7.1 *Blocked*
 - 7.2 *OFF*
 - 7.3 *Check up*
 - 7.4 *Ignition*
 - 7.5 *Run mode*
 - 7.6 *Modulation*
 - 7.7 *Standby*
 - 7.8 *Safety*
 - 7.9 *Shutdown*
8. *Final Cleaning*
 - 8.1 *Selecting Combustion Power*
 - 8.2 *Reducer Calibration*
 - 8.3 *Fan Calibration*
9. *Room Thermostat*

10. *Domestic Hot Water/Buffer Tank Probe*
11. *Electromagnetic Valve / Pump P2*
 - 11.1 *Pump P1*
12. *Shutdown During Ignition Phase*
13. *Power Failure*
14. *User Manual*
 - 14.1 *Connecting the Boiler to the Chimney*
 - 14.2 *Fuel*
 - 14.3 *Boiler Installation*
15. *Connection Dimensions*
 - 15.1 *Connecting the Pump and the Room Thermostat*
16. *First Ignition of the Boiler*
17. *Boiler Cleaning and Maintenance*
18. *Dismantling the Pellet Hopper*
19. *Electrical Wiring Scheme*
20. *Appendix*
21. *Table of Contents*