

TECHNICAL GUIDELINES FOR “ABC PRODUCT” BOILERS

1. Purpose and characteristics of the boiler

*Boiler type “ABC PRODUCT “is made for use of solid fuel, coal and dry wood. Boilers can work on liquid and gas fuel with the installation of an appropriate burner.

*According to YUS M.E6.201 and 202 boiler can be connected to installation with opened and closed system for keeping pressure, with water temperature of 110° Degrees C and maximum working pressure of 3 bars.

*Construction of boiler is making its cleaning and fire/making very simple. The reliable operation is provided as well as high degree of utilization, long life with adherence to recommendations with proper use which we are proving by 5 years guarantee.

*Boilers are made of certified boiler plate with guaranteed chemical composition and mechanic characteristics on higher temperatures, welded by the most advanced robot welding and technology of laser metal cutting. Examination of boilers is made on water with pressure of 3 bars.

*All connectors on boilers (outlet and inlet pipe line, chimney tube, connector for draft regulator) are in standard making and they do not need any specific adaptation.

*”**ABC PRODUCT**” boilers are recognizable by some elements and technical solutions which are not to be seen on similar products.

- ash shaker which prevents closure of space between tubes in fire-making place by products of burning and allows better supply of fresh air in area of burning. Handle for moving ash shaker is to be on the left or right side of the boiler.

- ashtray for easier collection of ash from boiler (at model for Classic, Economic, Supereco)

IMPORTANT NOTICE:

Ashtray's door must be closed during use of boiler; otherwise the temperature can increase without control above permitted level. That can cause damages on boiler and installations. Apart from that, it can also increase use of fuel.

The boiler is by standards delivered without a water heater, therefore it can be connected to the independent water heater.

For the boiler with liquid and gas fuel apart from burner it is necessary to implement command control panel as well as work's and marginal thermostat.

„**ABC PRODUCT**” boilers have very high degree of exploitation when used on liquid and gas fuel. According to test made at Mechanical Engineering in Nish, boiler Classic exploitation degree of has 90% and models Economic and Supereco even higher.

classic

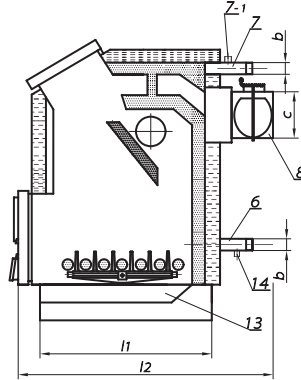
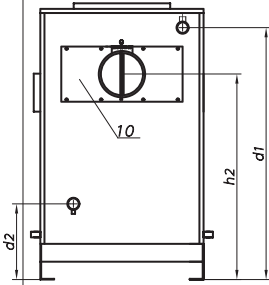

Picture number 1

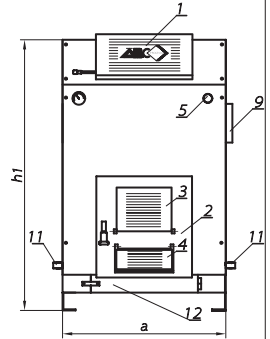

economic

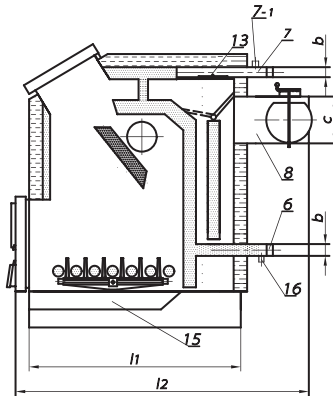
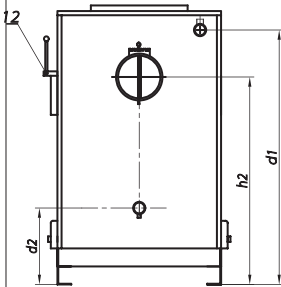

Picture number 2

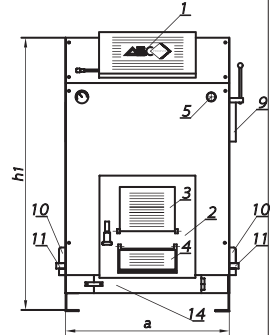

supereco

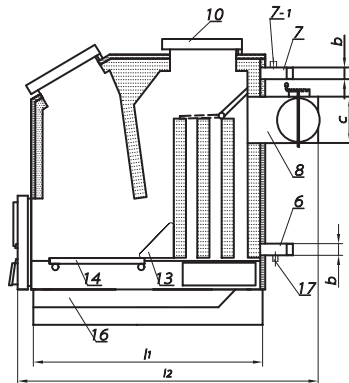
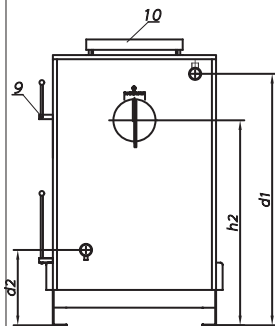

Picture number 3

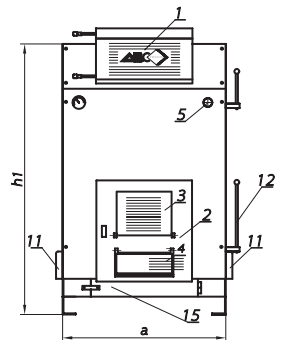

classic

TECHNICAL DETAILS	TYPE OF BOILER							
	ABC25	ABC30	ABC35	ABC40	ABC50	ABC60	ABC80	ABC100
Power(kw)*	25	30	35	40	50	60	80	100
Amount of water(l)	53	66	69	72	87	97	120	137
Mass (kg)	214	248	253	256	300	331	379	453
a (mm)	600	605	605	605	680	710	750	805
b (col)	R5/4	R5/4	R5/4	R5/4	R5/4	R6/4	R2	R2
c (mm)	ø160	ø160	ø160	ø160	ø180	ø180	ø180	ø200
d1 (mm)	985	1090	1120	1165	1175	1280	1425	1425
d2 (mm)	340	340	340	345	350	370	390	390
l1 (mm)	570	655	655	655	690	690	761	845
l2 (mm)	880	970	970	970	1010	1015	1040	1150
h1 (mm)	1090	1190	1225	1270	1275	1380	1530	1530
h2 (mm)	850	945	1005	1030	1030	1145	1280	1280
Necessary draft	15	16	18	20	22	24	27	30

1. Top door
2. Lower door
3. Door for burner
4. Hole cover of the secondary draft
5. Connector for draft regulator R ¾
6. Tube connector for return water
7. Tube connector for circulating water
- 7'. Connector for heat exchanger
8. Chimney tube
9. Hole for cleaning and hole for gas burner
10. Hole for cleaning from backside
11. Ash shaker
12. Ashtray's door
13. Ashtray
14. Connector for filling and emptying R ½

Rated capacity of the boiler is achieved at first fire-making with dry coal of calorific power..... and granulation cubes.
Change of type of fuel is causing change of power of boiler and change of degree of efficiency.

economic

TECHNICAL DETAILS	TYPE OF BOILER							
	ABC26	ABC33	ABC40	ABC55	ABC65	ABC75	ABC100	ABC130
Power(kw)*	26	33	40	55	65	75	100	130
Amount of water(l)	59	68	84	93	108	120	145	188
Mass (kg)	241	254	305	325	369	414	489	550
a (mm)	595	595	605	605	680	710	745	800
b (col)	R5/4	R5/4	R5/4	R5/4	R6/4	R6/4	R2	R2
c (mm)	ø160	ø160	ø160	ø180	ø180	ø180	ø200	ø200
d1 (mm)	985	985	1110	1190	1220	1310	1455	1480
d2 (mm)	350	350	365	390	390	390	395	400
l1 (mm)	690	690	780	818	828	881	885	985
l2 (mm)	975	975	1055	1055	1095	1140	1140	1255
h1 (mm)	1060	1060	1190	1275	1280	1380	1525	1545
h2 (mm)	820	820	940	1005	1045	1110	1275	1290
Necessary draft	22	22	24	26	27	29	33	35

1. Top door
2. Lower door
3. Door for burner
4. Hole cover of the secondary draft
5. Connector for draft regulator R ¾
6. Tube connector for return water
7. Tube connector for circulating water
- 7'. Connector for heat exchanger
8. Chimney tube
9. Hole for cleaning and hole for gas burner
10. Hole for cleaning
11. Ash shaker
12. Valve regulating flue of gases
13. Hole for cleaning from top side
14. Ashtray's door
15. Ashtray
16. Connector for filling and emptying R ½

This type of boiler has no front inclined tunnel.

Rated capacity of the boiler is achieved at first fire-making with dry coal of calorific power..... and granulation cubes.

Change of type of fuel is causing change of power of boiler and change of degree of efficiency.

supereco

TECHNICAL DETAILS	TYPE OF BOILER		
	ABC26	ABC32	ABC40
Power(kw)*	26	32	40
Amount of water(l)	107	121	136
Mass (kg)	391	409	437
a (mm)	570	605	670
b (col)	R5/4	R5/4	R5/4
c (mm)	ø180	ø180	ø180
d1 (mm)	1155	1155	1155
d2 (mm)	440	440	440
l1 (mm)	1030	1030	1030
l2 (mm)	1200	1200	1200
h1 (mm)	1250	1250	1250
h2 (mm)	930	930	930
Necessary draft	22	26	30

1. Top door
2. Lower door
3. Door for burner
4. Hole cover of the secondary draft
5. Connector for draft regulator R ¾
6. Tube connector for return water
7. Tube connector for circulating water
- 7'. Connector for heat exchanger
8. Chimney tube
9. Valve regulating flue of gases
10. Hole for cleaning from top side
11. Hole for cleaning from aside
12. Ash shaker
13. Hole for cleaning from top side
13. Part made of chamotte
14. Removable grid
15. Ashtray's door
16. Ashtray
17. Connector for filling and emptying R ½

Rated capacity of the boiler is achieved at first fire-making with dry coal of calorific power..... and granulation cubes.

Change of type of fuel is causing change of power of boiler and change of degree of efficiency.

dominant

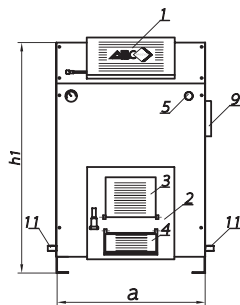
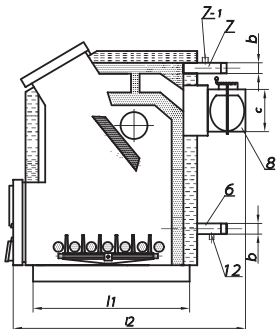
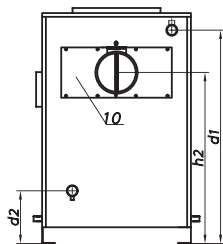

TECHNICAL DETAILS	TYPE OF BOILER							
	ABC25	ABC30	ABC35	ABC40	ABC50	ABC60	ABC80	ABC100
Power(kw)*	25	30	35	40	50	60	80	100
Amount of water(l)	53	66	69	72	87	97	120	137
Mass (kg)	196	229	235	237	279	309	341	408
a (mm)	600	605	605	605	680	710	750	805
b (col)	R5/4	R5/4	R5/4	R5/4	R5/4	R6/4	R2	R2
c (mm)	ø160	ø160	ø160	ø160	ø180	ø180	ø180	ø200
d1 (mm)	885	985	1025	1065	1070	1075	1320	1320
d2 (mm)	240	240	240	240	250	265	285	285
l1 (mm)	573	655	655	655	697	690	761	845
l2 (mm)	880	970	970	970	1010	1015	1040	1150
h1 (mm)	985	1090	1130	1170	1175	1280	1435	1435
h2 (mm)	755	860	890	930	940	1020	1165	1165
Necessary draft	15	16	18	20	22	24	27	30

1. Top door
2. Lower door
3. Door for burner
4. Hole cover of the secondary draft
5. Connector for draft regulator R ¾
6. Tube connector for return water
7. Tube connector for circulating water
- 7'. Connector for heat exchanger
8. Chimney tube
9. Hole for cleaning and hole for gas burner
10. Hole for cleaning from backside
11. Ash shaker
12. Connector for filling and emptying R ½

Rated capacity of the boiler is achieved at first fire-making with dry coal of calorific power..... and granulation cubes.
change of type of fuel is causing change of power of boiler and change of degree of efficiency.

dominant-extra

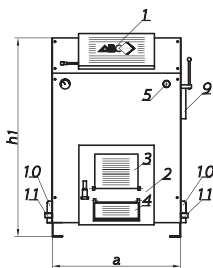
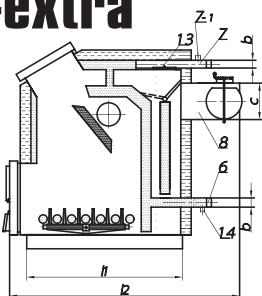
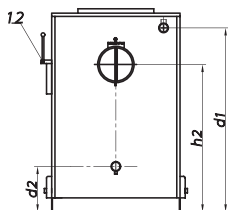

TECHNICAL DETAILS	TYPE OF BOILER							
	ABC26	ABC33	ABC40	ABC55	ABC65	ABC75	ABC100	ABC130
Power(kw)*	26	33	40	55	65	75	100	130
Amount of water(l)	59	68	84	93	108	120	145	188
Mass (kg)	228	240	287	292	342	385	460	520
a (mm)	595	595	605	605	680	710	745	800
b (col)	R5/4	R5/4	R5/4	R5/4	R6/4	R6/4	R2	R2
c (mm)	ø160	ø160	ø160	ø180	ø180	ø180	ø200	ø200
d1 (mm)	895	895	1020	1085	1115	1205	1365	1375
d2 (mm)	255	255	270	285	290	290	305	315
l1 (mm)	690	690	780	818	828	881	885	985
l2 (mm)	975	975	1055	1055	1095	1140	1140	1255
h1 (mm)	960	960	1090	1175	1180	1280	1430	1445
h2 (mm)	735	735	850	905	935	1015	1175	1190
Necessary draft	22	22	24	26	27	29	33	35

1. Top door
2. Lower door
3. Door for burner
4. Hole cover of the secondary draft
5. Connector for draft regulator R ¾
6. Tube connector for return water
7. Tube connector for circulating water
- 7'. Connector for heat exchanger
8. Chimney tube
9. Hole for cleaning and hole for gas burner
10. Hole for cleaning
11. Ash shaker
12. Valve regulating flue of gases
13. Hole for cleaning from top side
14. Connector for filling and emptying R ½

This type of boiler has no front inclined tunnel.

Rated capacity of the boiler is achieved at first fire-making with dry coal of calorific power..... and granulation cubes.
Change of type of fuel is causing change of power of boiler and change of degree of efficiency.

2. Selection and installation of boiler

Selection of boiler is made on base of projected capacity of the installation which is connected as well as the type of fuel the boiler is to work on.

INSTALLATION IS TO BE DONE BY PROFESSIONAL BODY.

Boiler must be installed on straight and stable surface, preferably in the separate room, not used for everyday living. It must have connection to the water supply (for filling installation), sewage disposal as well as connection to the electrical installation with earthing.

Room must have natural ventilation. Boiler must be placed in a way to be easy to get to all its elements for handling and all holes for cleaning. It is important to make proper connection of boiler with the chimney.

All compounds on boiler must be well sealed. That is to be visually checked before putting boiler in use.

Heat exchanger, Caleffi 3/4", type 544/501 on 100° C is to be put in already made connectors (position 7')

Draft regulator is to be put in already made connectors boiler (position 5) and by the chain is to be connected with hole cover for secondary draft (position 4, picture 1, 2, 3, 4 and 5). Recommendable draft regulators are: Regulus – Czech, ESBE – Sweden...

Assembling process is ending by filling boiler and the hole installation system by water up to the recommendable pressure, not higher than maximum work pressure of boiler.

Manufacturer recommends that after installation is finished the whole system should be tested "on cold" in duration of 1 hour to separate the air in installation.

3. FIRE-MAKING

Solid fuel must be physically separated from boiler by space or physical barrier. Dish for ash must be made of fireproof material and be placed outside the space for fuel (in cases where the model Dominant and Dominant - extra are installed because they do not have ashtray).

Storage of other types of fuel must be done by the regulations.

3. 1. MAKING FIRE FOR THE FIRST TIME

When making fire for the first time in boiler following conditions are to be filled:

- Chimney must be cleaned and properly connected to the boiler
- Boiler must have installed all security equipment
- Valve regulating draft in tube connection must be open and put towards axis of chimney tube
- System must be filled with water and all vents around boiler opened.

Further keeping fire on is to be made through some holes. After that the lower door is to be closed. Valve handle for fuel regulation on boilers such as type Economic (position 12, picture 2) must be on position "classic" and for the boilers type Supreco (position 9, picture 3) must be on position "economic" and for the boilers type Dominant extra(position 12, picture 5) must be in position "dominant" until boiler reaches temperature of 60° degrees C. Only then the handle is to be moved in previous position.

With installation without mixing valve, valves are to be closed on all heaters and reached temperature is to be maintained. Once fire is stable other heaters are to be gradually connected and recommended temperature reached and kept. When fire is stable and temperature is as recommended it is a time to go on regime "economic", "supereco", "dominant extra".

After reaching the given temperature the next is access to adjusting draft regulator per manufacturer's instructions.

IMPOTRANT NOTICE: There could be appearance of condensation when making a fire first time - there could be drops of water and appearance of humidity in ashtray. In this case slowly increase temperature in fireplace and condense will disappear when temperature reaches 80°- 90° degrees in boiler.

During first fire making there is a chance of appearance of characteristic smells of smoke, which is a consequence of burning of coating.

FIRST PUTTING IN USE OF BOILER IS TO BE DONE BY THE PROFESSIONAL BODY!

3.2. Use of solid fuel

Fire in boiler starts with the paper, small wooden parts, or "hepo cubes" with dry wood. Only when fire is made stable, shall we continue with the coal. Fire is to be made on lower door and further addition of fuel is to be done on top door.

Water temperature in boiler is to be adjusted by use of draft regulator (connector position 5, picture 1, 2,3,4,5 and always R3/4).Draft regulator is by chain connected to the hole cover for secondary draft by which air flow needed for burning is regulated.

IMPOTRANT NOTICE:

During firing circulation pump must be in use in every moment. In case of cessation of electrical energy supply, pump must be on accumulator or any other reserve supply(UPS or picture).In this case all holes on boiler for air supply are closed. It is prohibited to use water to extinguish fire in boiler.

In case these recommendations are not followed some damages can be caused. The manufacturer is not responsible for it.

Declared capacity and degree of utilization of the boiler are achieved by firing dry coal calorific Hd > 12500kj/kg and granulation>30mm. Boiler can be firing another types of coal as well as with dry wood and than capacity and degree of exploitation are changing. It is not allowed to burn rubber, plastic and organic materials in boiler. It is not recommended to use coniferous tree with resin or use of raw fuel. We are prohibited from watering solid fuel with any fuel or flammable liquids.

Important suggestion

Temperature of water in boiler should not go under 60°C.*

TABLE 1. Recommended water temperature in central heating radiators in correlation with the outdoor temperature

Tsp (°C) Outdoor temperature	-18	-15	-10	-5	0	5	10
Tv (°C) Water temperature	90	83	76	68	60	52	43

The table is an approximate and it depends on the relation between the isolation of the object and the size of the radiator.

Table is provisional and it depends of the isolation of the object and the size of radiators.

IT IS COMPULSARY to install mixing valve in order to avoid the appearance of condensation when temperature in radiators central heating system is fewer than 60°C as needed

Condensation is appearance of aerated water, like one of burning products. It appears on cold walls of firebox (under 60°C) as recommended at table 1. This is damaging as sumptuous acid from fuel is transforming into sulfuric acid which is damaging firebox surfaces made of steel.

By implementation of mix vent we are providing proper work and significant extension of life of our product.

IMPORTANT: The warranty is not recognize in the case mix vent is not implemented.

Recommendation of manufacturer:

1. For extended life of boiler and economical use of fuel we should not allow the temperature of water in boiler to go under 60° C.

2. Only boiler with the adequate power for the capacity of installation is to be used. Use of boiler with high power can cause condensation and is shortening the life of that product.

3. It is not recommended use of wet fuel as it is causing condensation.

4. The instillation of mix vent is a must in order to avoid appearance of condensation.

5. It is compulsory, for open and closed system (picture 10 and 11), to install heat exchanger Caleffi 544/501 (position 7' connection for heat exchanger), which provides protection of overheating. Heat exchanger Caleffi 544/501 is not in a basic boiler equipment.

In a case customer does not install heat exchanger Caleffi 544/501, and it comes to overheat of the boiler and damage on it, producer will not recognized warranty.

3.3. Firing liquid fuel and gas

Firing is beginning by burner start-up over adequate switch on dashboard. Prior to it is necessary to adjust operating thermometer on the desired water temperature. Grid in firebox behind lower door is to be removed as well as draft regulator. Hole cover for secondary draft is to be sealed.

During implementation of burner it is compulsory to use Technical instructions from manufacturer.

Probe for thermostat for work and border thermostat is to be put in the part of the boiler with the water through connection supply on its top side as per the picture number 8.

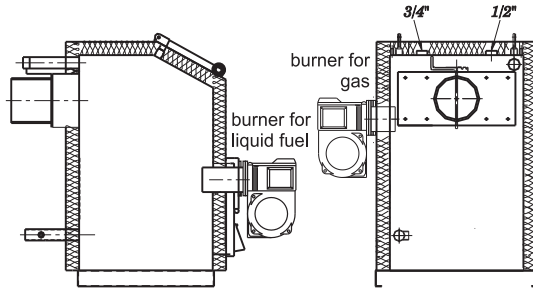

Picture number 6. Assembly of burner for liquid fuel and gas.

4. Chimney

Chimney is a very important part of central heating. It must be with recommended diameter, properly put, properly performed above roof and isolated. Dimensions of chimney are done by designer of installations based on capacity of boiler and type of fuel and necessary draft for chosen boiler. **Boiler is to achieve declared power only if the chimney is designed properly.**

Connection of boiler with the chimney is made by fumitory, tube with the equal diameter like chimney tube from the boiler. Maximum length of fumitory can be 1/3 of the chimney.

It is recommended to fuse in fumitory in chimney under angle of at least 15°.

Places of connection fumitory and chimney are to be sealed. Proper way of putting fumitory in chimney is shown of the picture number 7. Fumitory must be isolated.

Chimney must be properly performed above roof according to the instructions on the picture number 8. Implementation of chimney hats is to be avoided especially if they are on the side blinds. For eventual implementation of chimney hat it is recommended to go by the instructions on the picture number 9.

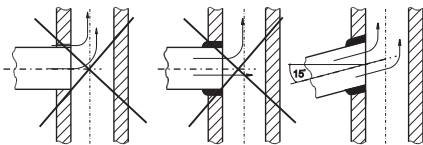

Picture number 7.
Implementation of chimney tube in chimney

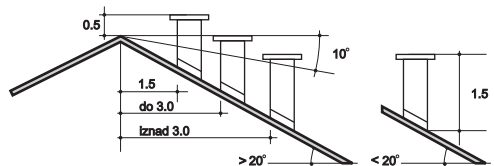

Picture number 8.
Implementation of the chimney above the roof

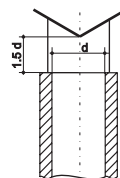

Picture number 9. How to set chimney cap

5. MEINTENACE OF BOILERS

In order to have a long use of boiler in good working conditions, it is necessary to have regular maintenance during use of it for heating and after that use, too.

Soot and tar which are accumulating on inside of the boiler during burning process are increasing use of heating material and decreasing degree of its exploitation. Therefore is necessary to control how dirty is the boiler during heating season and clean it when necessary, at least once a week.

The manufacturer suggests usage of chemical product for cleaning, which eases mechanical removal of remaining products of burning process. Manufacturer of this boiler can supply customer, in case he wants him to, all adequate chemical cleaning products.

When the heating season ends, the boiler is to be cleaned properly. Butterfly flue cap and its door on the boiler are to be left open.

The manufacturer recommends putting in a fire making space one clothed bag with 1-2 kg of lime when the heating season ends.

IMPORTANT: Pay attention to the location of holes for cleaning for every model of boiler. It can be noticed on the pictures at this technical instruction. It is compulsory to open them occasionally and to clean reachable surfaces in order to assure longevity of your boiler.

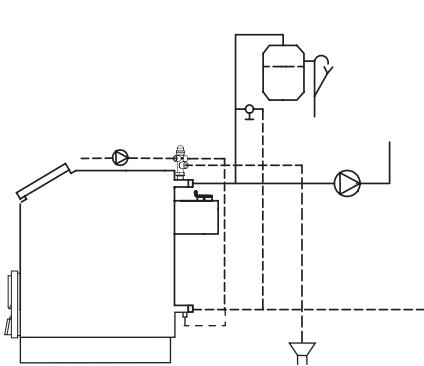

Picture number 10. Open system

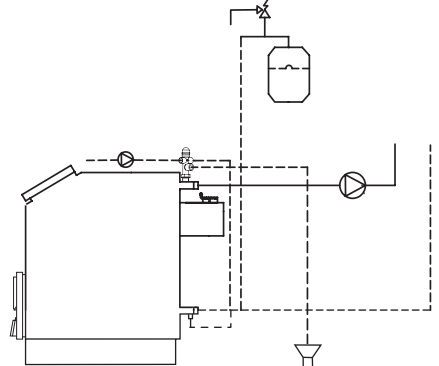

Picture number 11. Closed system

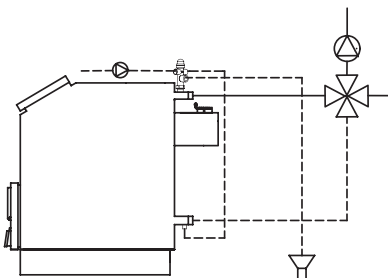

Picture number 12.
Regulation of room temperature

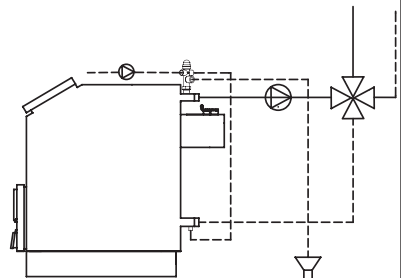

Picture number 13.
Regulation of returning water

6. ADDITION



COMPLIANCE WITH EU DIRECTIVES THESE BOILERS ARE IN COMPLIANCE WITH FOLLOWING EU DIRECTIVES:

97/23/EC- Equipment under pressure

92/42/EEC- Heaters for hot water

93/68/EEC- Heaters for hot water



COMPLIANCE WITH INTERNATIONAL STANDARDS

Quality managements system of "ABC PRODUCT" complies with the standard SRPS ISO9001/2001 and certified by the authorized institution. The boiler is manufactured and tested in accordance with the standards relating to heat generators with mandatory application for field use.



WARRANTY

ABC Boiler Factory guarantees for boilers Classic, Economic and Supereco for 5 (five) years and for boilers Dominant and Dominant-extra 2 (two) years.

Dear valued customers, if you are not satisfied with our products prior to deciding to get in touch with us for the intervention and use of our service please check the following:

1. Did you do all as instructed by INSTRUCTIONS when installing this product:

- choice of power of the boilers in relation to mediocrity and projected warming capacity
- height, cross section, the insulation of the chimney especially if the chimney was attached to the building
- proper execution of other parts of the heating installation that may affect the operation of the boiler
- security in case of interruption of electricity supply

2. Do you follow the prescribed heating regimen and maintenance of temperature of the boiler in terms of:

- appropriate choice of fuel -gradual firing -mandatory closure of ashtrays (for models equipped with an ashtray)
- use of ash shakers

3. Do you maintain the product properly in terms of cleaning soot and tar from the inside of the boiler and chimney

4. Did you make any unsolicited changes in your product

All of the above may affect the exercise of your right to a guarantee, lifetime of the boiler, installation and exposure to unnecessary costs in case of unjustified coming of our service at your field.